



STATE BANK OF PAKISTAN  
SBP BANKING SERVICES CORPORATION

Ref: No. IBD/Engg/527/24

Dated: 03-01-2024

**INVITATION TO BID**

**PROVIDING & FIXING OF MANUAL BARRIER IN FRONT OF MAIN GATE AT SBP BSC ISLAMABAD**

1. State Bank of Pakistan, Banking Services Corporation invites sealed bids from the contractors, registered with Income Tax Department and who are on Active Taxpayer list of the Federal Board of Revenue for Providing & Fixing of Manual Barrier in front of Main Gate at SBP BSC Islamabad.
2. Bidding documents containing detailed terms and conditions etc. are available at Office of the Engineering Unit, SBP BSC G-5/2, Islamabad (Ph. No. 051-9078304). The bidding documents can be obtained through an application on the letterhead of the firm/ company. Price of bidding documents for each tender is Rs. 1,000/- (Non-refundable) in the form of pay order/demand draft in favor of State Bank of Pakistan. Bidding documents can also be downloaded from SBP website at [www.sbp.org.pk](http://www.sbp.org.pk) free of cost and bidder can submit the bids on the said bidding documents in accordance with requirements. In case of any discrepancy/conflict, provisions of bidding documents including any addenda posted on the procuring agency website, shall prevail.
3. The bids prepared in accordance with the instructions provided in the Bidding documents must be delivered in a hard copy submitted (in person, or by post) at the address given below on or before 24<sup>th</sup> January, 2024 at 03:00 pm which shall be opened on the same day at 03:30 PM at Office of the PA to Chief Manager, 1<sup>st</sup> Floor, Main Bank Building, SBP BSC G-5/2 Islamabad in the presence of representatives of firms who may choose to be present. This advertisement is also available on websites: [www.sbp.org.pk](http://www.sbp.org.pk) & [www.ppra.org.pk](http://www.ppra.org.pk).

- Sd/-

Chief Manager  
State Bank of Pakistan  
SBP BSC (Bank) Islamabad  
Phone: 051-9078304



TWO VOLUMES  
Volume-I: Instructions to Bidders  
& Conditions of Contract  
Volume-II: Financial Bid

STATE BANK OF PAKISTAN  
SBP BANKING SERVICES CORPORATION  
ISLAMABAD

VOLUME-I

(Technical Proposal)

Bidding documents

For

---

**PROVIDING & FIXING OF MANUAL BARRIER IN FRONT OF MAIN GATE AT SBP BSC ISLAMABAD**

---

**BIDDING AND CONTRACT DOCUMENT**

INVITATION TO BID  
INSTRUCTIONS TO BIDDERS  
BIDDING DATA  
FORM OF BID  
QUALIFICATION CRITERIA  
CONDITIONS OF CONTRACT  
STANDARD FORM  
DRAWINGS  
SPECIFICATIONS

**January-2024**





Sr. No.	DESCRIPTION
1.	Bidding Documents Section-1-Part-1- (Instructions to Bidders)
2.	Bidding Documents Section-1-Part-2 – (Bidding Data)
3.	Bidding Documents Section-1-Part-3 – (Form of Bid)
4.	Bidding Documents Section-1-Part-4- (Schedules to Bid)
5.	Bidding Documents Section-2-Part-1- (Conditions of Contract)
6.	Bidding Documents Section-2-Part-2- (Contract Data)
6.	Bidding Documents Section-3-Part-1- (Standard Forms)
7.	Specifications
8.	Drawings



(Bidding Documents, Section-1, Part-1)

**INSTRUCTIONS TO BIDDERS****TABLE OF CONTENTS**

<b>Clause No.</b>	<b>Description</b>
<b>A.</b>	<b>GENERAL</b>
IB.1	Scope of Bid & Source of Funds
IB.2	Eligible Bidders
IB.3	Cost of Bidding
<b>B.</b>	<b>BIDDING DOCUMENTS</b>
IB.4	Contents of Bidding Documents
IB.5	Clarification of Bidding Documents
IB.6	Amendment of Bidding Documents
<b>C.</b>	<b>PREPARATION OF BID</b>
IB.7	Language of Bid
IB.8	Documents Comprising the Bid
IB.9	Sufficiency of Bid
IB.10	Bid Prices, Currency of Bid & Payment
IB.11	Documents Establishing Bidder's Eligibility and Qualifications
IB.12	Documents Establishing Works Conformity to Bidding Documents
IB.13	Bid Security
IB.14	Validity of Bids, Format, Signing and Submission of Bid
<b>D.</b>	<b>SUBMISSION OF BID</b>
IB.15	Deadline for Submission, Modification & Withdrawal of Bids
<b>E.</b>	<b>BID OPENING AND EVALUATION</b>
IB.16	Bid Opening, Clarification and Evaluation
IB.17	Process to be Confidential
IB.18	Contacting SBP BSC
<b>F.</b>	<b>AWARD OF CONTRACT</b>
IB.19	Award Criteria & Employer's Right
IB.20	Notification of Award
IB.21	Performance Security
IB.22	Signing of Contract Agreement
IB.23	Integrity Pact
IB.24	Rates inclusive of all taxes
IB.25	Code of conduct
IB.26	Overriding effect
IB.27	One Bid per Bidder
IB.28	Beneficial Ownership Information



## INSTRUCTIONS TO BIDDERS

### A. GENERAL

#### IB.1. Scope of Bid & Source of Funds

##### 1.1. Scope of Bid

The Employer as defined in the Bidding Data (hereinafter called “the Employer”) wishes to receive Bids for the works summarized in the Bidding Data (hereinafter referred to as “the Works”). Bidders must quote for the complete scope of works. Any Bid covering partial scope of works will be declared non-responsive.

##### 1.2. Source of Funds

The Employer has arranged funds from its own sources.

#### IB.2. Eligible Bidders

2.1. This Invitation for Bids is open to all persons, firms or companies dealing in the similar Works and not have been blacklisted or in litigation with any government department, autonomous body or any other organization. Bidders shall not be under a declaration of ineligibility for corrupt and fraudulent practices issued by the Employer or any other organization. Firms owned wholly or partly by persons having business interests with any official of the Employer / Consultant responsible for preparation of bidding documents, specifications and procurement of the works in whatsoever capacity cannot participate in the bidding process. .

##### 2.2. Bidding Procedure

Bidding shall be conducted using the National Competitive Bidding Procedure specified in the PPRA Rules-2004, **Rule-36(b) i.e. Single stage – two envelope procedure**. The bid shall comprise a single package containing two separate envelopes. Each envelope shall contain separately the Financial Proposal and the Technical Proposal. The envelopes shall be marked as “FINANCIAL PROPOSAL” and “TECHNICAL PROPOSAL” in bold and legible letters to avoid confusion. Initially, only the envelope marked “TECHNICAL PROPOSAL” shall be opened and the envelope marked as “FINANCIAL PROPOSAL” shall be retained in the custody of the Employer without being opened. The Employer will evaluate the technical proposal in a manner prescribed in Schedule B to Bid, without reference to the price and reject any proposal which does not conform to the specified requirements.

#### IB.3. Cost of Bidding

3.1. The bidder shall bear all costs associated with the preparation and submission of its bid and the Employer will in no case be responsible or liable for those costs, regardless of the conduct or outcome of the bidding process.

### B. BIDDING DOCUMENTS

#### IB.4. Contents of Bidding Documents

4.1. In addition to Invitation for Bids, the Bidding Documents are those stated below, and should be read in conjunction with any Addendum issued in accordance with Sub-Clause IB.6.1.

##### 4.2. Instructions to Bidders & Bidding Data

##### 4.2.1. Form of Bid & Schedules to Bid.

Schedules to Bid comprise the following:

- |      |             |  |
|------|-------------|--|
| i.   | Schedule A: | Schedule of Prices   |
| ii.  | Schedule B: | Post Qualification information and Bid Evaluation Criteria |
| iii. | Schedule C: | Specific Works Data  |
| iv.  | Schedule D: | Works to be performed by Sub-Contractors                   |
| v.   | Schedule E: | Proposed Methodology/ Work Program of the Bidder           |
| vi.  | Schedule F: | Integrity Pact   |

##### 4.3. Conditions of Contract & Contract Data

##### 4.4. Standard Forms:

- a. Form of Performance Security
- b. Form of Contract Agreement



- c. Form of Mobilization Advance
  - d. Form of Indemnity Bond
- 4.5. Specifications (if any)
- 4.6. Drawings (if any)

**IB.5. Clarification of Bidding Documents**

- 5.1. A prospective bidder requiring any clarification(s) in respect of the Bidding Documents may notify the Employer at the Employer’s address.
- 5.2. The Employer will respond to any request for clarification which it receives not later than ten (10) days prior to the deadline for the submission of Bids. Copies of the Employer’s response will be forwarded to all prospective bidders, who have received the Bidding Documents including a description of the enquiry but without identifying its source.

**IB.6. Amendment of Bidding Documents**

- 6.1. At any time prior to the deadline for submission of Bids, the Employer may, for any reason, whether at his own initiative or in response to a clarification requested by a prospective bidder, modify the Bidding Documents by issuing addendum.
- 6.2. Any addendum thus issued shall be part of the Bidding Documents pursuant to Sub-Clause 6.1 hereof, and shall be communicated in writing to all purchasers of the Bidding Documents. Prospective bidders shall acknowledge receipt of each addendum in writing to the Employer.
- 6.3. To afford prospective bidders reasonable time in which to take an addendum into account in preparing their Bids, the Employer may at its discretion extend the deadline for submission of Bids.

**C. PREPARATION OF BIDS**

**IB.7. Language of Bid**

- 7.1. The bid prepared by the bidder and all correspondence and documents relating to the Bid, exchanged by the bidder and the Employer shall be written in the English or Urdu language, provided that any printed literature furnished by the bidder may be written in another language so long as accompanied by an English or Urdu translation of its pertinent passages in which case, for purposes of interpretation of the Bid, the English or Urdu translation shall govern.

**IB.8. Documents Comprising the Bid**

- 8.1. The bid shall comprise the following documents:

**8.1.1. Technical Proposal;**

- a. Covering Letter on company letter head.
- b. Form of Bid duly filled & signed and stamped in accordance with IB.14.3.
- c. Schedules (B to E) to Bid duly filled and initialed, in accordance with the instructions contained therein & in accordance with Sub-Clause IB14.3.
- d. Bidder’s ‘Company Profile’ including list of tools, equipment and other facilities owned by the Bidder.
- e. Bidding Documents (in original) duly signed and stamped on each page/sheet (excluding Schedule-A (Schedule of Prices)).
- f. Power of Attorney in accordance with Sub-Clause IB 14.5.
- g. Documentary evidence in accordance with Clause IB.11
- h. Documentary evidence in accordance with Clause IB.12.
- i. Bid Security in line with IB-13

**8.1.2. Financial Bid;**



- a. Bidding Documents Schedule-A (Schedule of Prices), in original, duly signed and stamped on each page/sheet.

**IB.9. Sufficiency of Bid**

- 9.1. Each bidder shall satisfy himself before Bidding as to the correctness and sufficiency of his Bid and of the rates and prices entered in the Schedule of Prices, which rates and prices shall except in so far as it is otherwise expressly provided in the Contract, cover all his obligations under the Contract and all matters and things necessary for the proper completion of the Works.
- 9.2. The bidder is advised to obtain for himself at his own cost and responsibility all information that may be necessary for preparing the bid and entering into a Contract for execution of the Works.
- 9.3. The Bidders, at their own responsibility, risk & cost, are encouraged to visit and examine the site and obtain all information that may be necessary for preparing the Bid and entering into a contract for the Works.

**IB.10. Bid Prices, Currency of Bid and Payment**

- 10.1. The bidder shall fill up the Schedule of Prices (Schedule-A to Bid) indicating the unit rates and prices of the Works to be executed under the Contract. Prices in the Schedule of Prices shall be entered in Pak Rupees keeping in view the instructions contained in the Preamble to Schedule of Prices.
- 10.2. Unless otherwise stipulated in the Conditions of Contract, prices quoted by the bidder shall remain fixed during the bidder's performance of the Contract and not subject to variation on any account.
- 10.3. The unit rates and prices in the Schedule of Prices shall be quoted by the bidder in the currency as stipulated in Bidding Data.

**IB.11. Documents Establishing Bidder's Eligibility and Qualifications**

- 11.1. Bidder must possess and provide evidence of its capability and the experience as stipulated in Schedule-B to bid (Post-Qualification information and Bid Evaluation Criteria).

**IB.12. Documents Establishing Works Conformity to Bidding Documents**

- 12.1. The documentary evidence of the Work's conformity to the Bidding documents may be in the form of literature, drawings and data and the bidder shall furnish documentation as set out in Bidding Data.
- 12.2. The bidder shall note that standards for workmanship, material and equipment, and references to brand names or catalogue numbers, if any, designated by the Employer in the Technical Provisions are intended to be descriptive only and not restrictive.

**IB.13. Bid Security**

- 13.1. Each bidder shall furnish, as part of his bid a Bid Security in the amount stipulated in Bidding Data in Pak. Rupees in the form of Deposit at Call, Bank Draft or Pay Order issued by a Scheduled Bank in Pakistan in favour of the Employer valid for a period up to twenty eight (28) days beyond the bid validity date.
- 13.2. Any bid not accompanied by an acceptable Bid Security shall be rejected by the Employer as non-responsive.
- 13.3. The bid securities of unsuccessful bidders will be returned upon award of contract to the successful bidder or on the expiry of validity of Bid Security whichever is earlier.
- 13.4. The Bid Security of the successful bidder will be returned when the bidder has furnished the required Performance Security, pursuant to Clause IB.21 and signed the Contract Agreement, pursuant to Sub-Clauses IB.22.



- 13.5. The Bid Security may be forfeited:
- a. If a bidder withdraws his bid during the period of bid validity; or
  - b. If a bidder does not accept the correction of his Bid Price, or
  - c. In the case of a successful bidder, if he fails to:
    - i. Furnish the required Performance Security in accordance with Clause IB.21, or
    - ii. Sign the Contract Agreement, in accordance with Sub-Clauses IB.22.
- 13.6. In any event as specified in IB: 13.5, the Employer at his sole discretion may award works to second most advantageous bid.

**IB.14. Validity of Bids, Format, Signing and Submission of Bid**

- 14.1. Bids shall remain valid for the period stipulated in the Bidding Data after the date of bid opening.
- 14.2. All Schedules to Bid are to be properly completed and signed.
- 14.3. No alteration is to be made in the Form of Bid except in filling up the blanks as directed. If any alteration be made in the Form of Bid or any other part of Bidding Documents, or if these instructions be not fully complied with, the bid may be rejected.
- 14.4. Each bidder shall prepare Original and number of copies specified in the Bidding Data of the documents comprising the bid as described in Clause IB.8 and clearly mark them "ORIGINAL" and "COPY" as appropriate. In the event of discrepancy between them, the original shall prevail.
- 14.5. The original and all copies of the bid shall be typed or written in indelible ink and shall be signed by a person or persons duly authorized to sign (in the case of copies, Photostats are also acceptable). This shall be indicated by submitting a written Power of Attorney authorizing the signatory of the bidder to act for and on behalf of the bidder. All pages of the bid shall be initialed and official seal be affixed by the person or persons signing the bid.
- 14.6. In accordance with Clause IB-8, Technical Proposals & Financial Proposals shall be sealed in separate envelopes clearly marking the "Technical Proposal" & "Financial Proposal" and then both envelopes sealed in an outer envelope addressed to the Employer, with description of the contract and a warning regarding not to open before the specified date & time.

**D. SUBMISSION OF BIDS**

**IB.15. Deadline for Submission, Modification & Withdrawal of Bids**

- 15.
- 15.1. Bids must be received by the Employer at the address/provided in Bidding Data not later than the time and date stipulated therein.
- 15.2. Bids submitted through telegraph, telex, fax or e-mail shall not be considered.
- 15.3. Any bid received by the Employer after the deadline for submission prescribed in Bidding Data will be returned unopened to such bidder.
- 15.4. Any bidder may modify or withdraw his bid after bid submission provided that the modification or written notice of withdrawal is received by the Employer prior to the deadline for submission of bids.
- 15.5. Withdrawal of a bid during the interval between the deadline for submission of bids and the expiration of the period of bid validity specified in the Form of Bid may result in forfeiture of the Bid Security pursuant to Sub-Clause IB.13.5 (a).

**E. BID OPENING AND EVALUATION**





**IB.16. Bid Opening, Technical Qualification, Clarification and Evaluation**

- 16.1. The Employer will open the Technical Proposals in the presence of bidders' representatives who may choose to attend, at the time, date and location stipulated in Bidding Data.
- 16.2. The Employer will conduct post-qualification of the bidders in line with the stipulations of Schedule-B to Bid (Technical Bid Evaluation Criteria) on the basis of documents provided by Bidder. Bids shall be evaluated according to the provisions of Schedule-B to Bid (Technical Bid Evaluation Criteria). Any bid not meeting the requirements of Schedule-B shall be rejected and declared as non-responsive. The Bidders should submit detailed technical data regarding the services and brochures of the offered equipment and materials etc.
- 16.3. After finalization of Technical qualification results, the Employer will open publicly, the Financial Proposals of technically accepted bid(s), in the presence of bidders' representatives who may choose to attend, at the time, date and location.
- 16.4. The bidder's name, Bid Prices, any discount, the presence or absence of Bid Security, and such other details as the Employer at its discretion may consider appropriate, will be announced by the Employer at the bid opening. Representatives of the bidders who choose to attend shall sign the attendance sheet.
- 16.5. To assist in the examination, evaluation and comparison of Bids the Employer may, at its discretion, ask the bidder for a clarification of its Bid. The request for clarification and the response shall be in writing and no change in the price or substance of the Bid shall be sought, offered or permitted.
- 16.6. The Financial Bids of bidders found technically non-responsive/ not-qualified shall be returned unopened to the respective bidders. During tender evaluation no amendment in the bid is allowed.
- 16.7. Arithmetical errors will be rectified on the following basis:
- If there is a discrepancy between the unit price and total price that is obtained by multiplying the unit price and quantity, the unit price shall prevail and the total price shall be corrected. If there is a discrepancy between the words and figures the amount in words shall prevail.
- If the bidder does not accept the corrected amount of Bid, his Bid will be rejected and his Bid Security shall be forfeited.
- 16.8. Any minor informality or non-conformity or irregularity in a Bid which does not constitute a material deviation may be waived by Employer, provided such waiver does not prejudice or affect of any other bidders.
- 16.9. The Employer will evaluate and compare only the bids previously determined to be substantially responsive and Post-qualified pursuant to Sub-Clauses IB.16.4 to 16.9 as per requirements given hereunder. Bids will be evaluated for complete scope of services. The prices will be compared on the basis of the Evaluated Bid Price pursuant to Sub-Clause 16.11 herein below.
- 16.10. Evaluated Bid Price;
- In evaluating the bids, the Employer will determine for each bid in addition to the Bid Price, the following factors (adjustments) in the manner and to the extent indicated below to determine the Evaluated Bid Price:
- i. making any correction for arithmetic errors pursuant to Sub-Clause 16.7 hereof.
  - ii. making an appropriate price adjustment for any other acceptable variation or deviation.
  - iii. discount, if any, offered by the bidders.
- 16.11. After opening and scrutinizing the Financial Bids, the bids having item rates which are found imbalanced (abnormally high/low rates than market/ Engineer's estimate) will be rejected unless the bidder provides the justifiable rate analysis corresponding to the Engineer's Estimate. The payments against such running bills will be made as provided in clause 11 (b) of Conditions of Contract.
- 16.12. No alternate proposal(s) shall be entertained. Bidders offering more than one proposal(s) shall



be disqualified and its bid shall be deemed to be non-responsive.

**IB.17. Process to be Confidential**

17.1. Subject to Sub-Clause IB.16.5 heretofore, no bidder shall contact Employer on any matter relating to its Bid from the time of the Bid opening to the time the bid evaluation results are announced by the Employer. The evaluation results shall be announced as under:

- a. Technical Evaluation Report would be hoisted for Seven days on SBP website and on Notice Board of the office
- b. Financial / Final Evaluation Report would be hoisted for fifteen days on PPRA and SBP websites and on Notice Board the office

17.2. Any effort by a bidder to influence Employer in the Bid evaluation, Bid comparison or Contract Award decisions may result in the rejection of his Bid and will be blacklisted as per provisions of Public Procurement Rules, 2004. Whereas, Any bidder feeling aggrieved by any act of the procuring agency after the submission of his bid may lodge a written complaint concerning his grievances to Grievance redressal committee (GRC) as provided in Bid Data Sheet within seven days of announcement of the technical evaluation report and five days after issuance of final evaluation report.

**F. AWARD OF CONTRACT**

**IB.18. Post Qualification**

18.1. The Employer, at any stage of the bid evaluation, having credible reasons for or *prima facie* evidence of any defect in supplier's or contractor's capacities, may require the suppliers or contractors to provide information concerning their professional, technical, financial, legal or managerial competence whether already technically qualified or not:

Provided that such qualification shall only be laid down after recording reasons therefor in writing. They shall form part of the records of that bid evaluation report.

**IB.19. Award Criteria & Employer's Right**

19.1. Subject to IB.19.2, the Employer will award the Contract to the bidder whose bid has been found most advantageous bid i-e the bid which has been determined to be substantially responsive to the eligibility criteria and other terms of Bidding Documents and which is the lowest evaluated Bid Price.

19.2. Notwithstanding Sub-Clause IB.19.1, the Employer reserves the right to accept or reject any bid, and to annul the bidding process and reject all bids, at any time prior to award of Contract, without thereby incurring any liability to the affected bidders or any obligation to inform the affected bidders of the grounds for the Employer's action except that the grounds for its rejection of all bids shall upon request be communicated, to any bidder who submitted a bid, without justification of the grounds. Notice of the rejection of all the bids shall be given promptly to all the bidders.

**IB.20. Notification of Award**

20.1. Prior to expiration of the period of bid validity prescribed by the Employer, the Employer will notify the successful bidder in writing ("Letter of Acceptance") that his bid has been accepted.

**IB.21. Performance Security**

21.1. The successful bidder shall furnish to the Employer a Performance Security in the form and the amount stipulated in the Conditions of Contract within a period of fourteen (14) calendar days after the receipt of Letter of Acceptance.

21.2. Failure of the successful bidder to comply with the requirements of Sub-Clauses IB.21.1 and / or IB.22 shall constitute sufficient grounds for the annulment of the award and forfeiture of the Bid Security.



**IB.22. Signing of Contract Agreement**

- 22.1. The Contractor will prepare Contract Agreement in the Form of Contract Agreement provided in the Bidding Documents, incorporating all agreements between the parties. All cost in this regard including stamp duty shall be borne by the Contractor
- 22.2. The formal Agreement between the Employer and the successful bidder shall be executed within seven (07) days of the receipt of Form of Contract Agreement.

**IB.23. Integrity Pact**

- 23.1. The Bidder shall sign and stamp the Form of Integrity Pact provided at Schedule-F to Bid in the Bidding Document for all Federal Government procurement contracts exceeding Rupees ten (10) million. Failure to provide such Integrity Pact shall make the bid non-responsive.

**IB.24. Rates inclusive of all taxes**

- 24.1. The quoted rates should be inclusive of all applicable taxes, duties, liabilities, overheads, transportation charges etc. The exemption in Taxes will only be allowed against the Exemption Certificate issued by the relevant Tax Department. The bidders should be registered with all applicable tax departments.

**IB.25. Code of Conduct**

- 25.1. It is the Employer's policy that Contractors to observe the highest standards of ethics during the procurement and execution of contracts. In pursuit of this policy, the Employer follows, inter alia, the instructions contained in PPR-2004 which defines:

"blacklisted" means a bidder that is declared by the Authority untrustworthy after establishing the fact that the bidder was found involved in any corrupt and fraudulent practice or practices; or if the bidder is declared incapable by the Authority due to its established performance failure during the execution of the contract; or if the bidder deviates from its prior commitment or declaration made regarding the bid or proposal submitted by the bidder.

"corrupt and fraudulent practices" in respect of procurement process, shall be either one or any combination of the practices including,-

- i. "coercive practices" which means any impairing or harming or threatening to impair or harm, directly or indirectly, any party or the property of the party to influence the actions of a party to achieve a wrongful gain or to cause a wrongful loss to another party;
  - ii. "collusive practices" which means any arrangement between two or more parties to the procurement process designed to stifle open competition for any wrongful gain, and to establish prices at artificial, non-competitive levels;
  - iii. "corrupt practices" which means the offering, giving, receiving or soliciting, directly or indirectly, of anything of value to influence the acts of another party for wrongful gain;
  - iv. "fraudulent practices" which means any act or omission, including a misrepresentation, that knowingly or recklessly misleads, or attempts to mislead, a party to obtain a financial or other benefit or to avoid an obligation; and
  - v. "obstructive practices" which means harming or threatening to harm, directly or indirectly, persons to influence their participation in a procurement process, or affect the execution of a contract;
- 25.2. Under PPR-2004, the Employer can inter alia blacklist bidders found to be indulging in corrupt or fraudulent practices. Such barring action will be duly publicized and communicated to the PPRA. Such matters would be referred to the Blacklisting Committee that is empowered to take action accordingly.



NATURE OF OFFENSE / FAULT	MEANS OF VERIFICATION
<b>Corruption</b>	Actual instance verifiable as per law of land and applicable rules and regulations of SBP
<b>Deviation from commitment</b>	If the bidder deviates from its prior commitment or declaration made regarding the bid or proposal submitted by the bidder.
<b>Fraud</b>	Cross verification of documentary undertakings submitted by Contractor/Bidder/Consultant/Supplier
<b>Collusion</b>	Results of Bid/Proposal analysis resulting in substantive evidence of collusion
<b>Performance Deficiencies</b>	Documented evidence in form of performance deficiencies not suitably responded or defended by Contractor/ Bidder/ Supplier/ Consultant

However such barring action shall be undertaken only after Contractor who is to be barred and blacklisted shall be accorded adequate opportunity of being heard. Decision of the Blacklisting Committee of SBP BSC will be final and conclusive.

- 25.3. The receipt for any money paid by the bidders will not be considered as any acknowledgement of payment to the Contractor unless such receipt is signed by a duly authorized officer of the Employer and Contractor shall be solely responsible for seeing that a proper receipt is provided.
- 25.4. Attention of bidders is drawn to Rule-32 of PPR-2004 whereby they are required to identify any discriminatory and difficult conditions, introduced by Employer which discriminates between bidders or that is considered to be met with difficulty. In ascertaining the discriminatory or difficult nature of any condition reference shall be made to the ordinary practices of that trade, manufacturing, construction business or service to which that particular procurement is related. However in certain conditions Employer may describe exceptions or preferences consistent with Rule-4 of PPR-2004.
- 25.5. Employer's policy requires that selected Contractor shall provide professional, objective, and impartial advice and services and at all times hold the Employer's interests paramount, strictly avoid conflicts with other assignments or their own corporate interests and act without any consideration for future work. Bidders have an obligation to disclose any situation of actual or potential conflict that impacts their capacity to serve the best interest of the Bank, or that may reasonably be perceived as having this effect. Failure to disclose said situations may lead to the disqualification of the bidder and termination of contract arising out of this procurement
- 25.6. Without limitation on the generality of the foregoing, Contractors and any of their affiliates, shall be considered to have a conflict of interest and shall not be recruited, under any of the circumstances set forth below:
- A Contractor that has been engaged by the Employer to provide goods, works or services other than consulting services for a project, and any of its affiliates, shall be disqualified from providing consulting services related to those goods, works or services. Conversely, Contractor hired to provide consulting services for the preparation or implementation of a project, and any of its affiliates, shall be disqualified from subsequently providing goods or works or services other than consulting services resulting from or directly related to the firm's consulting services for such preparation or implementation.
  - A Contractor (including its Personnel and Sub-Contractor(s) or any of its affiliates shall not be hired for any assignment that, by its nature, may be in conflict with another assignment of the Contractor to be executed for the same or for another client.
  - A Contractor (including its Personnel and Sub-Contractor(s) that has a business or family relationship with a member of the Bank's staff who is directly or indirectly involved in any part of (i) the preparation of the specifications of the goods, (ii) the selection process for such assignment, or (iii) supervision of the Contract, may not be awarded a Contract, unless the conflict stemming from this relationship has been resolved in a manner acceptable to the appropriate authority of the Employer.
  - Bidders shall not recruit or hire any agency or current employees of the Bank. Recruiting former employees of the Employer or other civil servants to work for the bidders is acceptable provided no conflict of interest exists. When the Contractor nominates any government employee as Personnel in their bid, such Personnel must have written certification from their government or employer confirming that they are on leave without pay from their official position and allowed to work full-time outside of their previous official position. Such certification shall be provided to the Employer by the Contractor as part of bid.



**IB.26. Overriding Effect:**

26.1. The provision of Public Procurement Rules-2004 shall have prevailing effect.

**IB.27. One Bid per Bidder**

27.1. Each bidder shall submit only one bid either by himself, or as a partner in a joint venture. A bidder who submits or participates in more than one bid will be disqualified

**IB.28. Beneficial Ownership information**

28.1. For works worth Rs.50M or above, the bidder shall provide Beneficial Ownership information on the prescribed Form. Failure to provide the required information of the beneficial ownership by the company or submission of false or partial information, the procuring agency shall:

- i. Blacklist the said company in accordance with rule 19(1)(a) of Public Procurement Rules, 2004,
- ii. Reject the bid of the said company.



**BID DATA SHEET (BDS)**

The following specific data for goods and services to be procured shall complement, supplement, or amend the provisions in the Instructions to Bidders (ITB) Section III. Whenever there is a conflict between BDS and ITB, the provisions of BDS shall prevail over those in ITB.

<b>BDS 1.</b>	<b>The Employer</b>	<b>ITB 1.1</b>
State Bank of Pakistan, Banking Services Corporation (Bank) Islamabad		
<b>BDS 2.</b>	<b>Works</b>	<b>ITB 1.1</b>
PROVIDING & FIXING OF MANUAL BARRIER IN FRONT OF MAIN GATE AT SBP BSC ISLAMABAD		
<b>BDS 3.</b>	<b>Method of Procurement</b>	<b>ITB 2.2</b>
<p>Bidding shall be conducted using the National Competitive Bidding Procedure specified in the PPRA Rules-2004, <b>Rule-36(b) i.e. Single stage – two envelope procedure</b>. The bid shall comprise a single package containing two separate envelopes. Each envelope shall contain separately the Financial Proposal and the Technical Proposal. The envelopes shall be marked as “FINANCIAL PROPOSAL” and “TECHNICAL PROPOSAL” in bold and legible letters to avoid confusion. Initially, only the envelope marked “TECHNICAL PROPOSAL” shall be opened and the envelope marked as “FINANCIAL PROPOSAL” shall be retained in the custody of the Employer without being opened. The Employer will evaluate the technical proposal in a manner prescribed in Schedule B to Bid, without reference to the price and reject any proposal which does not conform to the specified requirements.</p>		
<b>BDS 4.</b>	<b>Employer Address</b>	<b>ITB 5.1</b>
State Bank of Pakistan, Banking Services Corporation (Bank) G-5/2 Islamabad		
<b>BDS 5.</b>	<b>Currency of Bid</b>	<b>ITB 10.3</b>
Bid shall be quoted entirely in Pak. Rupees. The payment shall be made in Pak. Rupees.		
<b>BDS 6.</b>	<b>Bid Security</b>	<b>ITB 13.1</b>
Each bidder shall furnish, as part of his bid a Bid Security of minimum Rs. 21,000/- in the shape of Pay Order / Demand Draft /Deposit at call in favor of <u>SBP-Banking Service Corporation</u> valid for a period 28 days beyond the Bid Validity date. The Bid Security in original is required to be submitted with Technical Bid.		
<b>BDS 7.</b>	<b>Bid Validity</b>	<b>ITB 14.1</b>
Bid Validity period is <b>180</b> days from the date fixed for opening of the Bids		
<b>BDS 8.</b>	<b>No. of Copies</b>	<b>ITB 14.4</b>
Only original Bid is to be submitted		
<b>BDS 9.</b>	<b>Address for Bid Submission</b>	<b>ITB 14.6 &amp; 15.1</b>
As mentioned in Invitation to Bid		
<b>BDS 10.</b>	<b>Deadline for Bid Submission</b>	<b>ITB 15.3</b>



As mentioned in Invitation to Bid	
<b>BDS 11. Address of Grievances Committee</b>	<b>ITB 17.2</b>
Chairman Grievances Committee, Office of the Director Human Resource Management Department 1st Floor, BSC House State Bank of Pakistan Main Building Complex, I.I.Chundrigar Road, Karachi	
<b>BDS 12. Performance Security</b>	<b>ITB 21.1</b>
a. In case, the cost of the Works is less than four million, The Bid Security of the successful bidder shall be retained as Performance Security.	
b. The Performance Security would remain valid till successful completion of Defect Liability Period and would be released after successful completion of defect liability period.	



FORM OF BID  
(LETTER OF OFFER)

Bid Reference No. \_\_\_\_\_

**PROVIDING & FIXING OF MANUAL BARRIER IN FRONT OF MAIN GATE AT SBP BSC ISLAMABAD**

To: Gentlemen,

1. Having examined the Bidding Documents including Instructions to Bidders, Bidding Data, Conditions of Contract, Contract Data, Specifications, Drawings, Schedule of Prices and Addenda Nos. \_\_\_\_\_ for the execution of the above-named Works, we, the undersigned, being a company doing business under the name of and address \_\_\_\_\_ and being duly incorporated under the laws of Pakistan hereby offer to execute the subject works and remedy any defects therein in conformity with the said Documents including Addenda thereto for the Total Bid Price as stated in Volume-II: Schedule of Prices or such other sum as may be ascertained in accordance with the said Documents.
2. We understand that all the Schedules attached hereto form part of this Bid.
3. As security for due performance of the undertakings and obligations of this Bid, we submit herewith a Bid Security as specified in bidding documents **IB.13 "Bid Security"**
4. We undertake, if we qualify and our Bid is accepted, to commence the whole Works comprised in the Contract within stipulated time for completion as mentioned in the bidding documents.
5. We agree to abide by this Bid for the period of **180** days from the date fixed for opening the same and it shall remain binding upon us and may be accepted at any time before the expiration of that period.
6. Unless and until a formal Agreement is prepared and executed, this Bid, together with your written acceptance thereof, shall constitute a binding contract between us.
7. We undertake, if our Bid is accepted, to provide the Performance Security referred to in Conditions of Contract for the due performance of the Contract.
8. We understand that you are not bound to accept the most advantageous bid or any bid you may receive.
9. We do hereby declare that the Bid is made without any collusion, comparison of figures or arrangement with any other person or persons making a bid for the Works.

Dated this \_\_\_\_\_ day of \_\_\_\_\_, 2024

Signature \_\_\_\_\_ in the capacity of \_\_\_\_\_ duly authorized to sign bid for and on behalf of the \_\_\_\_\_ ( name of Bidder)

(Name of Bidder in Block Capitals)  
(Seal)  
Address

Witness:  
(Signature) \_\_\_\_\_

Name: \_\_\_\_\_

Address: \_\_\_\_\_





**(Bidding Documents, Section-1, Part-4)**

**SCHEDULES TO BID INCLUDE THE FOLLOWING**

1. Schedule A to Bid: Schedule of Prices
2. Schedule B to Bid: Qualification Information and Bid Evaluation Criteria
3. Schedule C to Bid: Specific Works Data
4. Schedule D to Bid: Works to be Performed by Subcontractors
5. Schedule E to Bid: Proposed Methodology/ Work Program of the Bidder
6. Schedule F: to Bid Integrity Pact



**SCHEDULE OF PRICES  
(Financial Bid)**

---- REFER TO VOLUME-II OF THE BIDDING DOCUMENTS ----



**TECHNICAL BID EVALUATION CRITERIA****1. Qualification Criteria****1.1. General**

Qualification will be based on all the criteria given in succeeding para. Employer reserves the right to waive minor deviations, if these don't materially affect the capability of an applicant to perform the contract. Joint Venture or consortium is not allowed. The Employer reserves the right to seek further information and / or verify the information furnished by the applicants. In this regard, Employer reserve the right to have site visit to verify the previous installation /work experience etc. The Employer may reject any application for any misrepresentation knowingly made by any applicant in, or pursuant to, their application or for any statement furnished in connection therewith, and intended to be relied upon by the Employer, which is incorrect in any respect.

**1.2. Parameters of Bid Evaluation & Qualification**

SNO.	Description	Annexure / Page No. of attached Document
1.	Bid is un-conditional, conditional bids shall be rejected.	
2.	Duly filled and signed Form of Bid.	
3.	Bid Security as required in clause IB-13	
4.	Bidder must be registered with FBR in Income Tax and must be active taxpayer as per Federal Board of Revenue (FBR's) revenue Data base i-e Active Tax Payer List.	
5.	Bidder shall be held non-responsive if Bidder's name is found in Schedule-IV ( <a href="https://nacta.gov.pk/proscribed-persons-2/">https://nacta.gov.pk/proscribed-persons-2/</a> ) and list of organizations / Splinter Outfits <a href="https://nacta.gov.pk/proscribed-organizations/">https://nacta.gov.pk/proscribed-organizations/</a> notified by National Counter Terrorism Authority NACTA Pakistan	
6.	For works worth Rs.50M or above, the bidder shall provide Beneficial Ownership information on the prescribed Form.	
7.	<ul style="list-style-type: none"> <li>i. Name of Company</li> <li>ii. Company Legal Status: (Tick Anyone and provide relevant documents) <ul style="list-style-type: none"> <li>1. In case of Individual / Sole Proprietor <ul style="list-style-type: none"> <li>a) Copy of CNIC</li> <li>b) Affidavit that firm is individual / Sole proprietor</li> </ul> </li> <li>2. In case of Associated of Persons (AOP) <ul style="list-style-type: none"> <li>a) Partnership Deed</li> <li>b) No. of Partners along with CNIC</li> </ul> </li> <li>3. In case of (Pvt.) limited <ul style="list-style-type: none"> <li>a) Copy of Article of Association / Memorandum</li> <li>b) Form 29, Form A and Nos of Directors along with copy of CNIC</li> </ul> </li> </ul> </li> <li>iii. Contact details, <ul style="list-style-type: none"> <li>a) Telephone, Mobile No. , Fax numbers(if any), email address (if any)</li> <li>b) Postal Address</li> </ul> </li> </ul>	
8.	Affidavit on non-judicial stamp paper (Rs. 100/- denomination) of <b>not being blacklisted</b> , declared in-eligible or debarred by any organization / department for corrupt or fraudulent practices, or no failure to perform with SBP BSC in past.	
9.	Bidder shall also -provide the satisfactory performance certificates issued by the Bank (SBP BSC). If timely completion of project as per work program and cost is not achieved in any of the previous Contracts executed by the bidder to the Bank (SBP BSC) in the last three years, the bidder shall be held non-responsive.	



10.	The Bidder should also be registered with relevant / concerned Revenue Authority. If not registered, the 100% tax shall be deducted at source as per applicable law and credited to relevant account.	
11.	Valid registration with Pakistan Engineering Council at least in Category or above with specialization category (specialization category depending upon nature of work and cost is to be inserted). (The PEC requirement would not be applicable for projects less than Rs, 4 million).	
12.	Minimum two (2) works (construction/repair/ renovation/ maintenance) of cost R. 0.6 Million or more each, executed during last 5 (five) years (Work order/ completion certificates to be attached).	
13.	Minimum available Liquid assets of Rs. 0.40 Million (Bank statement of three months produced between date of publication of tender notice and bid submission date be submitted as evidence showing required balance at any one instant in the statement of last three months)	
14.	Acceptance of the Proposed Work Program as given in Schedule-E to Bid or submission of Work Program proposed by the bidder with overall project duration as mentioned in the contract data.	



**SPECIFIC WORKS DATA**

**1. Location of Site:**

“State Bank of Pakistan, Bank services Corporation (Bank), Islamabad”

**2. Major Items of Contract:**

TO BE INCORPORATED BY OFFICE BASED ON THE SCOPE OF WORK. FOR EXAMPLE;

“PROVIDING & FIXING OF MANUAL BARRIER IN FRONT OF MAIN GATE AT SBP BSC ISLAMABAD but not limited to;

- a. Dismantling of existing manual barrier carefully and stacking at designated location.
- b. Installation of existing barrier in front of other gate including excavation and concrete work.
- c. Providing & fixing of new barrier including all civil works.



**WORKS TO BE PERFORMED BY SUBCONTRACTORS**

..... Sub-Contracting Not Allowed .....



**Proposed Methodology/ Work Program**

Bidder shall provide a program in a bar chart showing the sequence of work items by which he proposes to complete the Works of the entire Contract. The program should indicate the sequence of work items and the period of time during which he proposes to complete the Works including the activities like designing, schedule of submittal of drawings, ordering and procurement of materials, manufacturing, delivering, construction of civil works, erection, testing and commissioning of Works to be supplied under the Contract. The proposed sequence of execution of various sections of the project shall be according to the given Key Performance Indicators (KPIs) as following;

For Example a template of such chart is annexed below;

Sr.	Description of Activity	Total Days	Start Date	Finish Date	Execution Scheduled Days					
					0-15	16-30	31-45	46-60	61-75	76-90
01	Dismantling of existing Barrier	15			■					
02	Stacking of existing material and additional materials at designated place inside Bank	05				■				
03	Installation of new manual barrier including all requisite works	60					■	■	■	■
04	Punch list items	10								■

The above Key Performance Indicators should be taken into consideration by the bidder in order to execute the works.

Signatures:

Stamp:

If the above KPI is not acceptable to any bidder, the bidder will prepare its own Work Program along with detailed justification for its change. Bids without above given Work Program or bidder's own proposed Work Program without justification shall not be considered responsive.



**(INTEGRITY PACT)**

(On non-judicial stamp paper worth Rupees 100)

**DECLARATION OF FEES, COMMISSION AND BROKERAGE ETC PAYABLE BY THE SUPPLIERS OF GOODS, SERVICES & WORKS IN CONTRACTS WORTH RS 10.00 MILLION OR MORE**

**Contract No.** \_\_\_\_\_ **Dated:-** \_\_\_\_\_  
**Contract Value:** \_\_\_\_\_  
**Contract Title:** \_\_\_\_\_

\_\_\_\_\_(name of Bidder)\_\_\_\_\_ hereby declares that it has not obtained or induced the procurement of any contract, right, interest, privilege or other obligation or benefit from State Bank of Pakistan -BSC(SBP-BSC) or State Bank of Pakistan and its Subsidiaries through any corrupt business practice.

Without limiting the generality of the foregoing, \_(name of Bidder)\_\_\_\_\_ represents and warrants that it has fully declared the brokerage, commission, fees etc. paid or payable to anyone and not given or agreed to give and shall not give or agree to give to anyone within or outside Pakistan either directly or indirectly through any natural or juridical person, including its affiliate, agent, associate, broker, consultant, director, promoter, shareholder, sponsor or subsidiary, any commission, gratification, bribe, finder’s fee or kickback, whether described as consultation fee or otherwise, with the object of obtaining or inducing the procurement of a contract, right, interest, privilege or other obligation or benefit in whatsoever form SBP-BSC except that which has been expressly declared pursuant hereto.

\_\_\_\_\_(name of Bidder)\_\_\_\_\_ certifies that it has made and will make full disclosure of all agreements and arrangements with all persons in respect of or related to the transaction with SBP-BSC and has not taken any action or will not take any action to circumvent the above declaration, representation or warranty.

\_\_\_\_\_(name of Bidder)\_\_\_\_\_ accepts full responsibilities and strict liability for making any false declaration, not making full disclosure, misrepresenting facts or taking any action likely to defeat the purpose of this declaration, representation and warranty. It agrees that any contract, right, interest, privilege or other obligation or benefit obtained or procured as aforesaid shall, without prejudice to any other rights and remedies available to SBP-BSC under any law, contract or other instrument, be void able at the option of the SBP-BSC.

Notwithstanding any right and remedies exercised by SBP-BSC in this regard, \_\_\_\_(name of bidder)\_\_\_\_\_ agrees to indemnify SBP-BSC for any loss or damage incurred by it an account of its corrupt business practices and further pay compensation to SBP-BSC in an amount equivalent to ten time the sum of any commission, gratification, bribe, finder’s fee or kickback given by \_\_\_\_(Name of Bidder)\_\_\_\_\_ as aforesaid for the purpose of obtaining or inducing the procurement of any contract, right, interest, privilege or other obligation or benefit in whatsoever form from SBP-BSC  
Name of Buyer: \_\_\_\_(SBP-BSC)\_\_\_\_\_

Signature: \_\_\_\_\_  
(Seal)

Name of Supplier/Bidder: \_\_\_\_\_  
Signature: \_\_\_\_\_

(Seal)





**Bidding Documents, Section-2, Part-1)****CONDITIONS OF CONTRACT****TABLE OF CONTENTS**

<b>Clause No.</b>	<b>Description</b>
1.	General Provisions
2.	The Employer
3.	Engineer's/Employer's Representatives
4.	The Contractor
5.	Employer's Right
6.	Employer's Risks
7.	Time for Completion
8.	Taking Over
9.	Remedying Defects
10.	Variations And Claims
11.	Contract Price And Payment
12.	Default
13.	Risks And Responsibilities
14.	Insurance
15.	Resolution of Disputes
16.	Integrity Pact
17.	Code of Conduct
18.	Overriding Effect
19.	Specifications and Epilogues
20.	Indemnification
21.	Confidentiality
22.	Independent Contractor
23.	Materials obtained / discovered during excavation
24.	Site clearance
25.	Health Safety, Environment and Security
26.	Utilities
27.	Attendance of Meetings
28.	First Aid facilities
29.	Utility Lines
30.	Others



## CONDITIONS OF CONTRACT

### 1. GENERAL PROVISIONS

#### 1.1 Definitions

In the Contract as defined below, the words and expressions defined shall have the following meanings assigned to them, except where the context requires otherwise:

##### The Contract

- 1.1.1 "Contract" means the Contract Agreement and the other documents listed in the Contract Data.
- 1.1.2 "Specifications" means the document as listed in the Contract Data, including Employer's requirements in respect of design to be carried out by the Contractor (if any), and any Variation to such document.
- 1.1.3 "Drawings" means the Employer's drawings of the Works as attached herewith, and any Variation to such drawings.

##### Persons

- 1.1.4 "Employer" means the person named in the Contract Data and the legal successors in title to this person, but not (except with the consent of the Contractor) any assignee.
- 1.1.5 "Contractor" means the person named in the Letter of Acceptance and the legal successors in title to this person, but not (except with the consent of the Employer) any assignee.
- 1.1.6 "Party" means either the Employer or the Contractor.

##### Dates, Times and Periods

- 1.1.7 "Commencement Date" means the date within fourteen (14) days after the date the Contract comes into effect or any other date named in the Letter of Award.
- 1.1.8 "Day" means a calendar day
- 1.1.9 "Time for Completion" means the time for completing the Works as stated in the Contract Data (or as extended under Sub-Clause 7.3), calculated from the Commencement Date.

##### Money and Payments

- 1.1.10 "Cost" means all expenditure properly incurred (or to be incurred) by the Contractor, whether on or off the Site, including overheads and similar charges but does not include any allowance for profit.

##### Other Definitions

- 1.1.11 "Contractor's Equipment" means all machinery, apparatus and other things required for the execution of the Works but does not include Materials or Plant intended to form part of the Works.
- 1.1.12 "Country" means the Islamic Republic of Pakistan.
- 1.1.13 "Employer's Risks" means those matters listed in Sub-Clause 6.1.
- 1.1.14 "Force Majeure" means an event or circumstance which makes performance of a Party's obligations illegal or impracticable and which is beyond that Party's reasonable control.
- 1.1.15 "Materials" means things of all kinds (other than Plant) to be supplied and incorporated in the Works by the Contractor.
- 1.1.16 "Plant" means the machinery and apparatus intended to form or forming part of the Works.
- 1.1.17 "Site" means the places provided by the Employer where the Works are to be executed, and any other places specified in the Contract as forming part of the Site.



- 1.1.18 "Variation" means a change which is instructed by the Engineer/Employer under Sub-Clause 10.1.
- 1.1.19 "Works" means any or all the works whether Supply, Installation, Construction etc. and design (if any) to be performed by the Contractor including temporary works and any variation thereof.
- 1.1.20 "Engineer" means the Engineer in-charge to be nominated in Letter of Acceptance.
- 1.1.21 Letter of Acceptance means the formal acceptance of the Bid by the Employer
- 1.1.22 Contract Price means the sum stated in the Letter of Acceptance as payable to the Contractor for execution and completion of the Works.

## 1.2 Interpretation

Words importing persons or parties shall include firms and organizations. Words importing singular or one gender shall include plural or the other gender where the context requires.

## 1.3 Priority of Documents

The documents forming the Contract are to be taken as mutually explanatory of one another. If an ambiguity or discrepancy is found in the documents, the priority of the documents shall be in accordance with the order as listed in the Contract Data.

## 1.4 Law

The law of the Contract is the relevant Law of Islamic Republic of Pakistan.

## 1.5 Communications

All Communications related to the Contract shall be in English/ Urdu language. A notice shall be effective only when it is delivered to the concerned party.

## 1.6 Statutory Obligations

The Contractor shall comply with the Laws of Islamic Republic of Pakistan and shall give all notices and pay all fees and other charges in respect of the Works.

## 2. THE EMPLOYER

### 2.1 Provision of Site

The Employer shall provide the Site and right of access thereto at the times stated in the Contract Data.

### 2.2 Permits etc.

The Employer shall, if required under law/ rules and requested by the Contractor, shall cooperate with the Contractor in applying and obtaining permits, licences or approvals etc. in context of the Contract.

### 2.3 Engineer's/Employer's Instructions

The Contractor shall comply with all instructions given by the Employer or the Engineer, if notified by the Employer, in respect of the Works including the suspension of all or part of the Works.

### 2.4 Approvals

No approval or consent or absence of comment by the Engineer/Employer shall affect the Contractor's obligations.

## 3. ENGINEER'S/EMPLOYER'S REPRESENTATIVES



The Employer shall appoint a duly authorized person (The Engineer In-charge), to act for him and on his behalf for the purpose of this Contract. This authorised person shall be fully authorised with respect to the Works except the authority to approve the variations, issuance of suspension and termination notices and sanctioning of the payments to be made to the Contractor under the Contract.

#### 4. THE CONTRACTOR

##### 4.1 General Obligations

The Contractor shall carry out the Works properly and in accordance with the Contract. The Contractor shall provide all supervision, labour, Materials, Plant and Contractor's Equipment which may be required.

##### 4.2 Contractor's Representative

The Contractor shall appoint a qualified representative at site on full time basis to supervise the execution of work and to receive instructions on behalf of the Contractor but only after obtaining the consent of the Employer for such appointment which consent shall not be unreasonable withheld by the Employer. Such authorized representative may be substituted/replaced by the Contractor at any time during the Contract Period but only after obtaining the consent of the Employer as aforesaid.

##### 4.3 Subcontracting

The Contractor shall not subcontract the whole of the Works. The Contractor shall not subcontract any part of the Works without the consent of the Employer.

##### 4.4 Performance Security

The Contractor shall furnish to the Employer within fourteen (14) days after receipt of Letter of Acceptance a Performance Security at the option of the bidder, in the form of Bank Draft or Bank Guarantee or an insurance company having at least AA rating from PACRA/JCR for the amount and validity specified in Contract Data.

##### 4.5 Contractor's Equipment

The Contractor shall have to bring at site of works and maintain the minimum construction equipment required for execution of works at site. Proper record of all such equipment shall be maintained by the Contractor and made available to the Employer as and when asked to do so. Prior approval of the Employer will be required for demobilization/shifting of any tool and plant from the site of works under this Contract

##### 4.6 Employer's Approvals

Contractor shall get approval of all the materials, fixtures and method statements well before the time from the Employer. The absence of supervisory staff or approvals or consent or comments from the Employer shall not affect the Contractor's obligations under the Contract.

##### 4.7 Observance of Law

Contractor shall strictly follow the applicable labour laws, industrial relations acts, standing orders, ordinances, social security acts, employees' old age benefits acts; workmen's compensation acts etc. in their letter and spirit and indemnify the Employer against any claim, compensation or penalty in this regard. This is an independent contract and no employment relation exists between the contractor and the Employer.

#### 5. Employer's Rights

Without prejudice to any other rights under the Contract and / or applicable law, Employer shall have following rights:



- i. The Employer reserves the right to change the scope of works during the executions of the Works; quantities of certain item(s) can be increased, decreased or absolutely deleted or substituted with some alternative item for which new rates shall be decided as per Clause-10.2.
- ii. The Employer reserves the right to reject a part or whole of the Works and hold any amount claimed by the Contractor against the items or Works for which, the prior approval of the samples was required by the Employer but was not obtained by the Contractor.
- iii. The Employer reserves the right to recover any amount from the payable amounts to the Contractor against any losses or damages incurred to the property, data, or persons of the Employer due to the Contractor or his workers negligence.
- iv. The Employer reserves the right to expel out any employee of the Contractor if found involved in a crime or illegal or unethical activities within or outside the Site.

The Contractor agrees that he shall have no right to claim any direct and / or indirect losses resultant of the above acts by the Employer.

## 6. EMPLOYER'S RISKS

### 6.1 The Employer's Risks

The Employer's Risks are:-

- a) war, hostilities (whether war be declared or not), invasion, act of foreign enemies, within the Country;
- b) rebellion, terrorism, revolution, insurrection, military or usurped power, or civil war, within the Country;
- c) riot, commotion or disorder by persons other than the Contractor's personnel and other employees including the personnel and employees of Sub-Contractors, affecting the Site and/or the Works;
- d) ionising radiations, or contamination by radio-activity from any nuclear fuel, or from any nuclear waste from the combustion of nuclear fuel, radio-active toxic explosive, or other hazardous properties of any explosive nuclear assembly or nuclear component of such an assembly, except to the extent to which the Contractor/Sub-Contractors may be responsible for the use of any radio-active material;
- e) Pressure waves caused by aircraft or other aerial devices travelling at sonic or supersonic speeds;
- f) use or occupation by the Employer of any part of the Works, except as may be specified in the Contract;
- g) late handing over of sites, anomalies in drawings, late delivery of designs and drawings of any part of the Works by the Employer's personnel or by others for whom the Employer is responsible;
- h) a suspension under Sub-Clause 2.3 unless it is attributable to the Contractor's failure; and
- i) physical obstructions or physical conditions other than climatic conditions, encountered on the Site during the performance of the Works, for which the Contractor immediately notified to the Employer and accepted by the Employer.

## 7. TIME FOR COMPLETION

### 7.1 Execution of the Works

The Contractor shall commence the Works on the Commencement Date as specified in the work order issued by the Employer and shall proceed expeditiously and without delay and shall complete the works within the time stipulated Contract Data observing all the time lines/target dates provided in the approved Work Program.

### 7.2 Work Program

The Contractor will have to prepare work program on the basis of Key Performance Indicators (KPIs) given in the Schedule-E to Bid or will submit work program its own assumption along with detailed justifications. Once the proposed Work Program has been approved by the Employer, it will have to be followed in letter & spirit.

Failure to perform according to the approved Work Program shall be considered as the Contractor's default and Employer reserves the right to invoke all or any remedy available in clause12.

### 7.3 Extension of Time

The Contractor shall, within such time as may be reasonable under the circumstances, notify the Employer of any event(s) falling within the scope of Employer's Risks, or Early Warnings, or adverse ground conditions, force majeure not leading to Contract termination, or any instruction of the



Employer to slow down the progress of works or change in the scope of Works by the Employer requiring additional time for completion of the Works as per the revised scope of Works, may request the Employer to extend the Completion Time reasonably. The Contractor must have to provide complete record of the circumstances on account of which extension of time is being applied along with an up-dated program/schedule in bar chart form for completion of the balance works. The Employer may evaluate the request lodged by the Contractor and extend the Completion Time. The decision of the Director/Head Engineering will be final & binding upon the Contractor.

It is being understood and agreed by the Contractor that the sole remedy for delay shall be extension in the time for performance of the Contractor's work, which extension shall not be subject to any valuation.

#### **7.4 Late Completion**

If the Contractor fails to complete the Works within the Time for Completion, the Employer without prejudice to any other rights under the Contract and / or applicable law shall deduct liquidated damages at rate as mentioned in the Contract Data.

### **8. TAKING-OVER**

#### **8.1 Completion**

The Contractor shall notify to the Employer along with As-built Drawings and Inventory List to issue the Provisional Completion Certificate and take over the Works when he considers that the Works are completed.

#### **8.2 Taking-Over Notice**

Within 15 days after receipt of notice, the Employer shall issue a Provisional Completion Certificate to the Contractor and take over the Works if the Works are substantially complete as per the Contract and to the entire satisfaction of the Employer.

If the Works are not completed to the entire satisfaction of the Employer, the Employer will issue a detailed account of the balance or defective works to the Contractor within fifteen (15) days after receipt of notice from the Contractor to take over the whole or a part of the Works. In case of minor defects/ outstanding Works, the Employer at its sole discretion, may take over the Works and issue the Provisional Completion Certificate after obtaining a written undertaking from the Contractor to rectify the punch list items/ outstanding Works during the Defects Liability period.

### **9. REMEDYING DEFECTS**

#### **9.1 Remediating Defects**

The Contractor shall for a period stated in the Contract Data from the date of issue of the Provisional Completion Certificate carry out, at no cost to the Employer, repair and rectification work which is necessitated by the earlier execution of poor quality of work or use of below specifications material in the execution of Works and which is so identified by the Employer/Engineer in writing within the said period. Upon expiry of the said period, and subject to the Contractor's faithfully performing his aforesaid obligations, the Employer/Engineer shall issue a Final Completion Certificate

Failure to remedy any such defects or complete outstanding work within a reasonable time shall entitle the Employer to carry out all necessary works at the Contractor's cost.

#### **9.2 Uncovering and Testing**

The Contractor shall give not less than five days' notice in writing to the Engineer-in-charge of work before covering up or otherwise placing beyond the reach of measurement any work in order that same may be measured, and correct dimensions thereof be taken before same is covered or placed beyond the reach of measurement.

The Engineer-in-Charge shall check the Contractor's Work and notify the Contractor of any Defects if found. Such checking shall not affect the Contractor's responsibilities. The Employer



may instruct the Contractor to search for a defect and to uncover/ or testing any work that the he considers may have a Defect

### 9.3 Failure to remedying Defects

Failure to remedy any defect(s) or complete the outstanding Works except the defects not attributable to the Contractor, to the entire satisfaction of the Employer within a notified time shall entitle the Employer to extend the defect liability period and / or carry out all necessary works at the Contractor's risk to cost in accordance with clause 12.

## 10. VARIATIONS AND CLAIMS

### 10.1 Right to Vary

The Employer/Engineer may issue Variation Order(s) in writing. Where for any reason it has not been possible for the Employer/Engineer to issue such Variations Order(s), the Contractor may confirm any verbal orders given by the Employer/Engineer in writing and if the same are not refuted/denied by the Employer/Engineer within seven (7) days of the receipt of such confirmation the same shall be deemed to be a Variation Orders for the purposes of this Sub-Clause.

### 10.2 Valuation of Variations

Variations shall be valued as follows:

- a) at a lump sum price agreed between the Parties, or
- b) where appropriate, at rates in the Contract, or
- c) rates notified by the Government Departments/agencies, or
- d) in the absence of appropriate rates, the rates in the Contract shall be used as the basis for valuation, or failing which
- e) at appropriate new rates, as may be agreed or which the Engineer/Employer considers appropriate, or

Contractor's profit & overheads shall be up to 15% of the cost of labour & materials, cartage, etc. Taxes shall be considered as per actual rate while analyzing rates for any extra items. For valuation of variations and approval of rates for non-BOQ/extra items, the decision of the Director Engineering will be final & binding upon the parties.

### 10.3 Early Warning

The Contractor shall notify the Engineer/Employer in writing as soon as he is aware of any circumstance which may delay or disrupt the Works, or which may give rise for Extension in time.

To the extent of the Contractor's failure to notify, which results to the Engineer/Employer being unable to keep all relevant records or not taking steps to minimize any delay, disruption, the Contractor's entitlement to extension of the Time for Completion may be reduced/rejected.

### 10.4 Variation Procedure

The Contractor shall submit to the Engineer/Employer an itemized make-up of the value of variations within twenty eight (28) days of the instruction. The Engineer/Employer shall check and if possible agree the value. In the absence of agreement, the Employer shall determine the value.

## 11. CONTRACT PRICE AND PAYMENT

### 11.1 (a) Terms of Payments

The Employer shall verify these bills and payments shall be released to the Contractor within **thirty (30)** days after joint verification of the bill by the Employer & the Contractor and after deduction of retention money, applicable taxes or any such other sum determined by the Employer.

### (b) Imbalanced Bid



In case of imbalanced bid (abnormally high/low rates than market/ Employer's Engineer's estimate) duly justified by the contractor, the payments against such running bills will be made by the employer up to 80% of the running bill after required deductions. The remaining amount will be settled at the time of final settlement upon completion of work to the satisfaction of the Employer.

#### **11.2 Submission of Statements of Work Done/ Interim Bills**

The Contractor shall submit the bills only after the payment against last or previously submitted bills has been made by the Employer.

#### **11.3 Interim Payments**

Within a period not exceeding seven (7) days from the date of submission of a statement for interim payment by the Contractor, the Engineer shall verify the same and within a period not exceeding thirty (30) days from the said date of submission by the Contractor, the Employer shall pay to the Contractor the sum verified by the Engineer less retention money at the rate stated in the Contract Data and all applicable taxes and duties.

#### **11.4 Retention Money**

Retention money shall be paid by the Employer to the Contractor after the expiry of defect liability period, the remedying of notified defects and the completion of outstanding work, all as referred to in Sub-Clause 9.1.

If the Contractor fails to complete the Works and rectification of any defects as per the entire satisfaction of the Employer under Clause-09, this Retention Money and Performance Security will be withheld by the Employer and it shall be released after adjustment of any claims against the Contractor or cost of any defects corrected through other sources or Contractors at the risk to cost of the Contractor.

#### **11.5 Final Payment**

Upon issuance of Final Completion Certificate, the payments pertaining to the Works completed during Defects Liability Period and / or money as Retention Money shall be released as per sub-Clause-11.4 and the accounts for the contract shall be closed. The Employer shall release payments within sixty (60) days.

#### **11.6 Currency**

Payment shall be in the currency stated in the Contract Data.

#### **11.7 Mobilization Advance**

If requested by the Contractor, an interest-free Mobilization Advance up to 15 % of the Contract Price stated in the Letter of Acceptance shall be paid by the Employer to the Contractor in two equal parts upon submission by the Contractor of a Mobilization Advance Guarantee for the full amount of the Advance in the specified form from a Scheduled Bank in Pakistan subject to approval of Director/Head Engineering Payments shall be made as per the following criteria;

- a) First part of the Mobilization Advance within twenty (20) days after verification of the approved/ legible Bank Guarantee from the issuing bank.
- b) Second part of the mobilization advance on arrival of required tools & plants and commencement of Works at site to the entire satisfaction of the Employer.

Mobilization Advance paid to the Contractor shall be recovered from the interim bills of the Contractor @ 15% of total amount of work done at site for the bill being processed till the time that whole of the amount of Mobilization Advance has been recovered.

#### **11.8 Secured Advance**

The Employer at his sole discretion may provide to Contractor Secured Advance against an indemnity bond acceptable to the Employer of such sum as the Engineer in charge may consider proper in respect of non-perishable materials brought at the Site but not yet incorporated in the permanent Works subject to approval of Director/Head of Engineering, provided that:





- (a) The materials are in accordance with the Specifications for the permanent works;
- (b) Such materials have been delivered to the Site and are properly stored and protected against loss or damage or deterioration to the satisfaction of the Engineer in charge but at the risk to cost of the Contractor;
- (c) The Contractor's records of the requirements, orders, receipts and use of materials are kept in a form approved by the Engineer in charge, and such records shall be available for inspection by the Engineer in charge;
- (d) The Contractor shall submit with his monthly statement the estimated value of the materials on Site together with such documents as may be required by the Engineer in charge for the purpose of valuation of materials and providing evidence of ownership and payment therefore;
- (e) Ownership of such materials shall be deemed to vest in the Employer and these materials shall not be removed from the Site or otherwise disposed of without written permission of the Employer.
- (f) 60% of the purchase price of the item/material or 50% of tender price of the item/material whichever is lesser, after measuring the quantity & verification of the quality of materials at site by the Employer may be paid

The amount of Secured Advance against any item(s)/materials shall be recovered from the next three (03) bill of the Contractor in the form of three equal installments. The Employer reserves the right to recover all outstanding amount of the Secured Advance from very 1<sup>st</sup> bill of the Contractor submitted after release of the Secured Advance.

#### 11.9 Changes in Taxes and Duties

If, after the date of submission of Bids, there occur changes in the taxes and duties which cause additional or reduced cost to the Contractor in the execution of the Contract, such additional or reduced cost shall be added to or deducted from the Contract Price accordingly. Decision of the Director/Head Engineering will be final & conclusive in this regard.

#### 11.10 Price Adjustment

Prices quoted by the Contractor shall remain fixed; no Price Adjustment shall be made for any variation in the market prices.

### 12. DEFAULT

#### 12.1 Default, Termination of the Contract and Compensation to the Employer

##### (a) Default by the Contractor:

If the Contractor abandons the Works, delays abnormally, or misses the target dates mentioned in the approved Work Program or refuses or fails to comply with a valid instruction of the Employer, or if Contractor materially or consistently breaches the Contract, the Employer may give a notice under this sub-clause stating the default. If the Contractor has not taken practicable steps to remedy the default or cover up the backlog within fifteen (15) days after receipt of the Employer's notice, the Employer may by serving a second notice within twenty five (25) days, terminate the Contract asking the Contractor to demobilize from the Site leaving behind the Equipment required for completion of the outstanding Works at risk & cost of the Contractor or the Employer may deploy extra resources to cover up the backlog at the risk & cost of the Contractor. The decision of the Director/Head Engineering will be final and conclusive in this regard.

##### (b) Default by the Employer:

If the Employer fails to pay in accordance with the Contract, or is, despite a written complaint, in breach of the Contract, the Contractor may give a notice under this sub-clause stating the default. If default is not remedied within fifteen (15) days by the Employer after receipt of the notice, the Contractor may suspend execution of all parts of the Works. If the default is not remedied within thirty (30) days after receipt of first notice, the Contractor may serve a second notice within thirty (30) days and terminate the Contract and demobilize from the Site.

##### (c) Employer's sole discretion:

The Employer shall be entitled to terminate the Contract, at any time for the Employer's convenience, by giving notice of such termination to the Contractor. The termination shall take effect within 15 days after the Contractor receives the notice.

##### (d) Insolvency:



If either part is declared (or is likely to be declared) insolvent under any applicable law, the other party may terminate the Contract by serving a notice immediately. The Contractor shall demobilize from the Site leaving behind the Equipment required for completion of the outstanding Works in case of Contractor's insolvency.

**(e) Criminal/ Offensive act by the Contractor or his employees:**

If the Contractor or any of his employees commits a serious crime within the premises of the Employer which can result in police action under Penal Code Act of Pakistan, the Employer may terminate the Contract by serving a notice to the Contractor and the Contractor shall demobilize from the Site leaving behind the Equipment required for completion of the outstanding Works at the risk & cost of the Contractor.

**(f) Actions in case of failure of the Contractor:**

If the Contractor fails to complete the Works even when the amount of Liquidated Damages has reached to the maximum fixed limit or the Contractor abandons or suspends the Works, or commits breach of the terms & conditions of the Contract, the Contractor or any of his employees commits a serious crime within the premises of the Employer which can result in police action under Penal Code Act of Pakistan or in any case in which the contractor shall have rendered himself liable to pay compensation/liquidated damages, the Director/Head Engineering whose decision shall be final & conclusive, without prejudice to any other right or remedies, shall have power to adopt all or any of the following courses as he may deem best suited to the interest of the Employer;

- i. To rescind the Contract (of which the rescission notice in writing to the Contractor under the hand of Director/Head Engineering shall be conclusive evidence) and in which case the retention money and Performance Security of the Contractor shall be forfeited and be absolutely at the disposal of the Bank;
- ii. To employ labour paid by the Employer and to supply materials to carry out the Works or any part of the Works, debiting the Contractor with the cost of all labour and the price of the materials (of the amount of which cost and price a certificate of the Director/Head Engineering shall be final & conclusive against the Contractor) and crediting him with the value of the work done in all respects in the same manner and at the same rates as if it had been carried out by the Contractor under the terms of this Contract; the certificate of the Director/Head Engineering as to the value of the work done shall be final and conclusive against the Contractor;
- iii. To measure up the works of the Contractor and to take such part thereof as shall be as shall be un-executed out of his hands and give it to another contractor to complete, in which case any expenses which may be incurred in excess of the sum which would have been paid to the original Contractor, if the whole had been executed by him (of the amount of which excess the certificate in writing of the Director/Head Engineering shall be final and conclusive) shall be borne and paid by the original Contractor and may be deducted from any money due to him by the Bank under the Contract or otherwise, or from his retention money or the proceeds of sale thereof or sufficient part thereof;
- iv. If any of the above courses being adopted by the Director/Head Engineering, the Contractor shall have no claim to compensation for any loss sustained by him by reasons or his having purchased or procured any materials, or entered in to any engagements or made any advances on account of, or with a view to the execution of the works or the performance of the Contract. And in case the Contract shall be rescinded under the provisions aforesaid, the Contractor shall not be entitled to recover or be paid any sum for any works theretofore actually performed under this Contract unless and until the Director/Head Engineering will have certified in writing the performance of such works and the value payable in respect thereof and he shall be only be entitled to be paid the value so certified.
- v. In case of Contractor's failure to perform in line with the agreed terms & conditions laid down in the contract, the Employer may blacklist the Contractor for future opportunities at the Employer as per clause 18.2 and decision of the Director/Head Engineering will be final & conclusive. As per Public Procurement Rule-19, the Contractor will be accorded adequate opportunity of being heard.

**(g) Payments upon Termination**

In case of termination by the Employer, the Contractor shall be entitled to payment of the unpaid balance of the value of the Works executed only after adjustment of any sums to which the Contractor is entitled and any sums to which the Employer is entitled



including recovery of all recoverable advance payments,. No payment shall be made against the leftover materials, machinery, plants etc. brought by the Contractor and against his demobilization. If the total amount already released by the Employer exceeds any payment due to the Contractor, the difference shall be a recovered from the balance payable amounts or the Retention Money along with the performance Security.

### 13. Warranty

- 13.1 The Contractor warrants that the goods supplied under the Contract are new, unused, of the most recent or current models, and that they incorporate all recent improvements in design and materials unless provided otherwise in the Contract. The Contractor further warrants that all goods supplied under this Contract shall have no defect, arising from design, materials, or workmanship (except when the design and/or material is required by the Procuring agency's specifications) or from any act or omission of the Contractor, that may develop under normal use of the supplied goods in the conditions prevailing in the country of final destination.
- 13.2 If the Contractor, having been notified, fails to remedy the defect(s) within a reasonable period, the Employer may proceed to take such remedial action as may be necessary, at the Contractor's risk and expense and without prejudice to any other rights which the Employer may have against the Contractor under the Contract.

### 14. RISKS AND RESPONSIBILITIES

#### 14.1 Contractor's Care of the Works

From the Commencement Date until the completion of Works and issuance of Completion Certificate or Termination by the Employer, the risks of loss or damage to Works, personal injury, death, and loss of or damage to property of the Employer due to the negligence of the Contractor, his employees, associates, sub-contractor, assigns etc. all such risks are Contractor's risks. The Contractor shall have to make good all damages/losses to the Employer after receiving written notice from the Employer.

Unless the loss or damage happens as a result of any of the Employer's Risks, the Contractor shall indemnify the Employer, or his agents against all claims loss, damage and expense arising out of the Works.

#### 14.2 Force Majeure

If the Contract is frustrated by a force majeure, like the outbreak of war, civil commotion, and insurrection or by any other event entirely outside the control of either the Employer or the Contractor, the Employer shall certify that the Contract has been frustrated and is being terminated. If an event of force majeure continues for a period of sixty (60) days, the Contractor can also give a notice of termination. The Contractor shall stop work as quickly as possible after receiving contract frustration certificate from the Employer and shall be paid for all work carried out or services rendered before the frustration/ termination of the Contract and for any work carried out afterwards to which a commitment was made including the cost of materials and plants reasonably delivered to the Site, after adjustment of any sums to which the Contractor is entitled as per the Contract, and cost of his demobilization after recovery of all recoverable advance payments made by the Employer or the sums to which the Employer is entitled. If the reason ceases to exist, the Parties can recommence the performance of the Contract under the original terms & conditions if mutually agreed.

### 15. INSURANCE

- 15.1 The Contractor shall on joint name of employer and Contractor procure a contractor's all risks of physical loss or damage insurance policy, covering all risk to Works, third party, and all risks of physical loss to labour or damage caused to the Contractor's plants, equipment, materials and any other asset(s) belonging to the Contractor.

Insurance Policy shall cover the damages to the structure, stores if supplied by the Employer caused by fire, including lightening, riots, strikes, storm, cyclones, flood, earthquake, theft, etc.

#### 15.2 Default



If the Contractor fails to effect or keep in force any of the insurances referred to in the previous Sub-Clause, or fails to provide satisfactory evidence, policies or receipts, the Employer may, without prejudice to any other right or remedy, effect insurance for the cover relevant to such as a default and pay the premiums due and recover the same plus a sum in percentage given in Contractor Data from any other amounts due to the Contractor.

## 16. RESOLUTION OF DISPUTES

- 16.1 If any dispute arises between the parties (Contractor & the Employer), the matter shall be referred to the Director/Head Engineering who will examine the matter in detail and give the decision which will be final & binding upon the parties.
- 16.2 In case the Contractor believes that the decision of the Director/Head Engineering was not in line with the Contract or it is prejudiced, and he does not accept the same, he may give a notice of dissatisfaction under this sub-clause within 15 days of the decision of the Director/Head Engineering. If no notice is given within this time, the decision of Director/Head Engineering shall be final and binding upon the Parties.
- 16.3 In case a dissatisfaction notice is given by the Contractor, the matter may be referred to a neutral Adjudicator appointed after mutual agreement within 15 days after the notice of dissatisfaction. Failing to agree upon Adjudicator name within the specified time will result in finality of the Director/Head Engineering's decision which will become binding upon the parties.
- 16.4 If required under any circumstances, the matter may be referred to arbitration under the Arbitration Act 1940 (Act No. X of 1940) and rules made there under and any statutory modifications thereto. Arbitration Proceedings shall be held at the place mentioned in the Contract Data.

## 17 INTEGRITY PACT

If the Contractor or any of his Sub-Contractors, agents or servants is found to have violated or involved in violation of the Integrity Pact signed by the Contractor as Schedule-F to his Bid, then the Employer shall be entitled to:

- (a) recover from the Contractor an amount equivalent to ten times the sum of any commission, gratification, bribe, finder's fee or kickback given by the Contractor or any of his Sub-Contractors, agents or servants;
- (b) Terminate the Contract; and
- (c) Recover from the Contractor any loss or damage to the Employer as a result of such termination or of any other corrupt business practices of the Contractor or any of his Sub-Contractors, agents or servants.

On termination of the Contract under Sub-Para (b) of this Sub-Clause, the Contractor shall demobilize from the Site leaving behind Contractor's Equipment which the Employer instructs, in the termination notice, to be used for the completion of the Works at the risk and cost of the Contractor.

## 18. CODE OF CONDUCT

- 18.1 It is the Employer's policy to Contractors observes the highest standards of ethics during the procurement and execution of such contracts. In pursuit of this policy, the Employer follows, inter alia, the instructions contained in PPR-2004 which defines:  
"corrupt and fraudulent practices" includes the offering, giving, receiving, or soliciting of anything of value to influence the action of a public official or the supplier or Firm/Company in the procurement process or in contract execution to the detriment of the procuring agencies; or misrepresentation of facts in order to influence a procurement process or the execution of a contract, collusive practices among Consultant/Service Providers (prior to or after Proposal submission) designed to establish bid Prices at artificial, non-competitive levels and to deprive the procuring agencies of the benefits of free and open competition and any request for, or solicitation of anything of value by any public official in the course of the exercise of his duty;"
- 18.2 Under Rule-19 of PPR-2004, "The Employer can inter alia blacklist bidders found to be indulging in corrupt or fraudulent practices. Such barring action will be duly publicized and communicated to the PPRA. Such matters would be referred to the Blacklisting Committee that is empowered to take action accordingly:



NATURE OF OFFENSE / FAULT	MEANS OF VERIFICATION
<b>Corruption</b>	Actual instance verifiable as per law of land and applicable rules and regulations of SBP
<b>Deviation from commitment</b>	If the bidder deviates from its prior commitment or declaration made regarding the bid or proposal submitted by the bidder.
<b>Fraud</b>	Cross verification of documentary undertakings submitted by Contractor/ Bidder/Consultant/Supplier
<b>Collusion</b>	Results of Bid/Proposal analysis resulting in substantive evidence of collusion
<b>Performance Deficiencies</b>	Documented evidence in form of performance deficiencies not suitably responded or defended by Contractor/ Bidder/ Supplier/ Consultant

However such barring action shall be undertaken only after Contractor who is to be barred and blacklisted shall be accorded adequate opportunity of being heard. Decision of Blacklisting Committee of SBP BSC will be final and conclusive.

- 18.3** The receipt for any money paid by the bidders will not be considered as any acknowledgement of payment to the Contractor unless such receipt is signed by a duly authorized officer of the Employer and Contractor shall be solely responsible for seeing that a proper receipt is provided.
- 18.4** Attention of bidders is drawn to Rule-32 of PPR-2004 whereby they are required to identify any discriminatory and difficult conditions, introduced by Employer which discriminates between bidders or that is considered to be met with difficulty. In ascertaining the discriminatory or difficult nature of any condition reference shall be made to the ordinary practices of that trade, manufacturing, construction business or service to which that particular procurement is related. However in certain conditions Employer may describe exceptions or preferences consistent with Rule-4 of PPR-2004.
- 18.5** Employer's policy requires that selected Contractor shall provide professional, objective, and impartial advice and services and at all times hold the Employer's interests paramount, strictly avoid conflicts with other assignments or their own corporate interests and act without any consideration for future work. Bidders have an obligation to disclose any situation of actual or potential conflict that impacts their capacity to serve the best interest of the Bank, or that may reasonably be perceived as having this effect. Failure to disclose said situations may lead to the disqualification of the bidder and termination of contract arising out of this procurement
- 18.6** Without limitation on the generality of the foregoing, Contractors and any of their affiliates, shall be considered to have a conflict of interest and shall not be recruited, under any of the circumstances set forth below:
- A Contractor that has been engaged by the Employer to provide goods, works or services other than consulting services for a project, and any of its affiliates, shall be disqualified from providing consulting services related to those goods, works or services. Conversely, Contractor hired to provide consulting services for the preparation or implementation of a project, and any of its affiliates, shall be disqualified from subsequently providing goods or works or services other than consulting services resulting from or directly related to the firm's consulting services for such preparation or implementation.
  - A Contractor (including its Personnel and Sub-Contractor(s) or any of its affiliates shall not be hired for any assignment that, by its nature, may be in conflict with another assignment of the Contractor to be executed for the same or for another client.
  - A Contractor (including its Personnel and Sub-Contractor(s) that has a business or family relationship with a member of the Bank's staff who is directly or indirectly involved in any part of (i) the preparation of the specifications of the goods, (ii) the selection process for such assignment, or (iii) supervision of the Contract, may not be awarded a Contract, unless the conflict stemming from this relationship has been resolved in a manner acceptable to the appropriate authority of the Employer.
  - Bidders shall not recruit or hire any agency or current employees of the Bank. Recruiting former employees of the Employer or other civil servants to work for the bidders is acceptable provided no conflict of interest exists. When the Contractor nominates any government employee as Personnel in their bid, such Personnel must have written certification from their government or employer confirming that they are on leave without pay from their official position and allowed to work full-time



outside of their previous official position. Such certification shall be provided to the Employer by the Contractor as part of bid.

**19. OVERRIDING EFFECT OF PPR-2004**

Whenever in conflict with these documents the stipulations of PPR-2004 (Public Procurement Rules-2004) shall prevail.

**20. SPECIFICATION EPILOGUES**

- a. The Work(s) contemplated under the Contract, shall be constructed, completed and guaranteed, strictly conforming to and in accordance with the stipulated specifications for execution of such works, providing of materials/services and etc. as provided in the Contract Documents and or as directed by the Employer.
- b. In the event of missing / non-availability of particular specification (s) applicable to or to govern the execution of such item(s) of works/ contract hereof, having no effect or bearing upon the rate/price or valuation of the contract, all material, fabrication, execution and testing thereof shall conform to the applicable standards, codes/specifications contained in the following list to equivalent applicable standard and specifications established and/or as approved in the country of manufacture or supply:

ASTM	American Society of Testing Materials
AASHTO	American Association of State Highway and Transportation Officials
AWWA	American Water Works Association
ASME	American Society of Mechanical Engineers
AISC	American Institute of Steel Construction
ASA	American Standards Association
AWS	American Welding Society
BSS	British Standard Specifications & Materials)
PSI	Pakistan Standards Institute

- c. All quality control and related tests (if required) shall be carried out in accordance with applicable standards and codes. The cost in this regard shall be borne by the Contractor.

**21. SILENCE OF SPECIFICATIONS**

The apparent silence of the specifications, plans, or other contract documents as to any detail or the apparent omission from them of a detailed description concerning any point, shall be regarded as meaning that only the best generally accepted practice is to be used. All interpretations of the specifications will be made by the Engineer on this basis.

**22. REMOVAL OF UNACCEPTABLE AND UNAUTHORIZED WORK**

All work which, as determined by the Engineer or Engineer In-charge, does not conform to the requirements of the Contract and results in an inferior or unsatisfactory product, will be considered unacceptable. Unacceptable Work, whether the result of poor workmanship, use of defective materials, damage through carelessness or any other cause, found to exist prior to the final acceptance of the Work, shall be removed or replaced at the Contractor's expense.

No work shall be done without lines and grades having been approved by the Engineer. Work done contrary to the instructions of the Engineer, Work done beyond the lines shown on the plans, or as given, except as herein specified, or any extra work done without authority, will be considered as unauthorized and will not be paid for under the provisions of the Contract. Work so done may be ordered removed or replaced at the Contractor's expense.

Upon failure on the part of the Contractor to comply forthwith with any order of the Engineer, made under the provisions of this article, the Engineer will have authority to cause unacceptable Work to be remedied or removed and replaced and unauthorized Work to be removed and to deduct the costs from any moneys due or to become due the Contractor

**23. The Contractor shall be liable & indemnify the Employer**

Contractor shall be exclusively liable for and shall indemnify and hold harmless the Employer,



its agents and employees from:

- a. Making good all losses arising out of the Contractor's negligence or breach of the Contract. The Employer shall determine the amounts of such losses/ damages and the Contractor hereby expressly waives his all or any right to change or challenge the same. The Contractor shall have to make good all such losses/ damages within time frame specified in the Notice, to the entire satisfaction of the Employer after receiving written notice from the Employer.
- b. All losses arising from the automatic transfer of employment of Contractor's and its sub-contractor's employees to premises or any third party on the expiry or termination of the Contract including, in relation to the employees:
  - i. All liabilities in respect of their employment before or after the expiry or termination of the Contract and
  - ii. The costs of terminating their employment and any claims arising there from.
- c. Any tax, government duties, insurance contributions (employee and employer) and or social security contributions in respect of Contractor (in the case of an individual) or any employee or sub-contractor of Contractor together in each case with any interest, fines or penalties thereon.
- d. Save for the willful or deliberate breach of its obligations under the Contract or, as set out above, neither party shall be liable for any consequential or indirect loss or damage.
- e. All payments to his staff and other hired persons, sub-contractors or assigns during the currency of this Contract or after its expiry/ termination. The Employer shall have no relation, in whatsoever way, with such employees or persons recruited, hired or contracted by the Contractor and all these persons shall always be treated as the employees of the Contractor.
- f. Any claims of his own, of his employees or ex-employees, or associates, or their heirs whether against the Contractor, other contractors working within the same premises or any other person, regarding deals made at personal level by the staff or personal matters or deals carried out as a company, in whatsoever form, manner or capacity.
- g. Any Government Permits, Licenses, etc. that may be required for performing the Works contemplated under the Contract.
- h. All claims of compensation by an employee, his family or legal heirs or any other agency, autonomous body, any NGO or government department, arising from injury, disability, ill health or death of any of his employees during the currency or expiry of this Contract while performing any services under this Contract or any claim regarding the medical care or treatment expenses submitted by the employee or ex-employee of the Contractor or their legal heirs.
- i. In case any claim of compensation, expense in whatsoever form is to be paid by the Employer under any law of the land, the same amount shall be deducted from the Contractor's payable amounts/retention money.
- j. Full cost and responsibility for his employees/ staff, under no circumstances, whatsoever, shall the Contractor or its employees shall be regarded as the Employer's employees, and there would be no employer / employee relationship between them and the Employer.

**24. Confidentiality**

Except with the consent in writing of the Employer, Contractor shall keep strictly confidential and not make use of any confidential information supplied by the Employer other than to perform this Contract, and shall impose the same obligations on its employees and other third parties (including sub-contractors).

**25. Independent Contractor**

The Contractor including all his employees, sub-contractors, associates, assigns or his legal heirs shall at all times function and be regarded as independent contractor and not as an agent of the Employer and neither the Contractor nor its employees, sub-contractors, associates, assigns or his legal heirs shall have the right to represent or bind the Employer to any third person including any department or agency of Government or any other authority in any manner, whatsoever.

**26. Materials Obtained/Discovered during excavation**

Materials obtained from excavation will be the property of the Employer. Serviceable materials & treasures etc. found shall have to be stacked/stored at the location designated by the Employer. All rubbish/un-wanted materials/debris shall have to be disposed of by the contractor in line with the directions of the Employer & municipal regulations.

**27. Site Clearance at completion**

On completion of the project/works or at some earlier stage as desired by the Employer, the contractor shall remove all temporary structures, dumpsites, debris, surplus materials, etc. and fill up all trenches etc. made during the execution of the works. The contractor will have to secure a site clearance certificate from the Employer and attaché the same with his final bill.



In case the contractor fails or refuses to do so, the Employer reserves the right to get it done through the other sources/contractors and deduct/recover the expenditure so occurred from the bills or retention money **along with the Performance Security submitted at the time of bid opening** of the contractor. In this regard, the decision of the Director/Head Engineering will be final & conclusive.

## 28. Health, Safety, Environment and Security (HSE&S)

- a. The Contractor shall comply with all statutory and regulatory requirements related to Health, Safety, Environment & Security (HSE&S) as well as Employer's applicable rules, procedures or policies related thereto at no additional cost to the Employer. The costs of supplying and/or doing all such things required for the purpose shall be deemed to be included in the amounts payable under this Agreement to the Contractor.
- b. The Employer shall periodically audit the Contractor's compliance with its HSE&S policies and conduct safety inspections as and when it deems fit. The Contractor shall ensure that Employer's recommendations in this regard are implemented without any delay.
- c. The Contractor shall provide the Employer information about its working practices, materials and equipment and shall operate in a manner which does not compromise Employer's security or environment standards and the safety and health of its employees and other people. Contractor shall also provide the Employer with any information which it may have related to a potential or actual security threat to the Employer.
- d. The Contractor shall certify in writing that its personnel are fully trained to execute the Works safely and shall ensure that they understand all risks and hazards associated with the Works. The Contractor shall keep records of such trainings.
- e. The Employer reserves the right to terminate this Contract without notice to the Contractor in the event of violation of this Clause by the Contractor and related HSE&S requirements of the Employer communicated to the Contractor from time to time.
- f. The Contractor shall pay special attention to the following environmental protection measures;
  1. Use of clean fuels to minimize air polluting emissions.
  2. Control of other air pollutants.
  3. Recovery and recycling of usable materials.
  4. Control of vehicle noise.
  5. Control of noise from power facilities.
  6. Limitation of Vibrations.
  7. Preservation of natural land to the extent possible.
  8. Preservation of archaeological Sites.
  9. Careful handling, storage and utilization of hazardous radioactive materials, toxic chemicals etc.

## 29. Electric Power Supply, Water supply, Telephone etc.

Water for construction purposes will be provided by the Employer. Electricity will be provided by the Employer for all minor equipment & tools. Expense regarding the required cables/wires and sub-meters, switches etc. shall have to be borne by the Contractor. The Contractor shall make his own arrangement at his own expenses for the telephone & fax etc. at the Site of Works. If these facilities are to be provided by the Employer at the request of the Contractor, the Contractor shall have to pay the bills/ expenses as per mutually agreed terms & conditions at that time. Hutting/ tenting etc. for the workers or storage of the materials of the contractor shall be the responsibility of the contractor.

## 30. Attendance of Meetings

The Contractor shall attend all meetings along with his authorized representative(s) when called by the Employer to discuss the quality and progress of Works, site matters and other matters related to the Contract, without any compensation from the Employer. The Contractor may ask the Employer to call a joint meeting to review the pending issues and decisions or to discuss any other matters, factors or aspects in context of the Contract. The minutes of meetings may be recorded and circulated amongst the participants for compliance.

## 31. First Aid Facilities

The contractor shall provide his staff with free first-aid facilities and treatment at the premises and shall, for this purpose, keep a properly equipped first aid kit at the premises.

## 32. Utility Lines

The Contractor shall conduct his operations, make necessary arrangements, take suitable precautions and perform all required work incident to the protection of and avoidance of interference with power transmission, telegraph, telephone and natural gas lines, oil lines, water and sewerage mains and other utilities within the areas of his operations in connection





with this Contract and the cost thereof shall be borne by the Contractor and the Contractor shall save harmless and indemnify the Employer in respect of all claims, demands, proceedings, costs, charges and expenses whatsoever arising out of or in relation to any such interference.

**33. Other**

- a. The terms and conditions and the Schedules thereto of this Contract represent the entire agreement and understanding between the Employer and the Contractor, in relation to the subject matter hereof and supersede all previous agreements and/or understandings between the parties in relation thereto.
- b. If any provision of the Contract is found by any court or competent authority to be invalid, unlawful or unenforceable, that provision shall be deemed not to be a part of the Contract and it shall not affect the enforceability of the rest of the Contract.
- c. Unless expressly provided, no term of this Contract is enforceable by any third party.
- d. This Contract is personal to Contractor and Contractor shall not assign or subcontract any of its rights or obligations under it without Employer's prior written consent. Any subcontracting shall be on terms consistent with these Conditions for the benefit of an enforceable by the Employer and Contractor shall remain liable for the subcontractor's acts and omissions and the Contract's complete performance.
- e. The Contract shall be governed by the laws of Pakistan and Contractor and the Employer agree to submit to the exclusive jurisdiction of the courts in Pakistan.

**34 Beneficial Ownership information**

For works worth Rs.50M or above, the bidder shall provide Beneficial Ownership information on the prescribed Form. Failure to provide the required information of the beneficial ownership by the company or submission of false or partial information, the procuring agency shall:

- i. Blacklist the said company in accordance with rule 19(1)(a) of Public Procurement Rules, 2004,
- ii. Reject the bid of the said company.



The following Contract Data shall be deemed to form and be read and constructed as part of the Contract, including Conditions of Contract.

### CONTRACT DATA

<b>SCC 1.</b>	<b>Employer</b>	<b>GCC Clause 1</b>
Means SBP-Banking Services Corporation Head Office Karachi		
<b>SCC 2.</b>	<b>Priority of Documents</b>	<b>GCC Clause 3</b>
Documents forming the Contract listed in the order of priority:		
(a) The Contract Agreement		
(b) Letter of Acceptance		
(c) The completed Form of Bid		
(d) Contract Data		
(e) Conditions of Contract		
(f) The completed Schedules to Bid including Schedule of Prices		
(g) The Drawings, if any		
(h) The Specifications, if any		
<b>SCC 3.</b>	<b>Amount of Performance Security</b>	<b>GCC Clause 4.4</b>
a. In case, the cost of the Works is less than four million, The Bid Security of the successful bidder shall be retained as Performance Security.		
The Performance Security would remain valid till successful completion of Defect Liability Period and would be released after successful completion of defect liability period.		
<b>SCC 4.</b>	<b>Completion Time</b>	<b>GCC Clause 7.1</b>
90 Calendar days		
<b>SCC 5.</b>	<b>Liquidated Damages</b>	<b>GCC Clause 7.4</b>
@ 0.1% of total work done/ day to a maximum of 10% of the total work done.		
<b>SCC 6.</b>	<b>Defect Liability Period</b>	<b>GCC Clause 9</b>
365 Calendar days		
<b>SCC 7.</b>	<b>Retention Money</b>	<b>GCC Clause 11.4</b>
10% of the net payable amount for each bill of the Contractor		
<b>SCC 8.</b>	<b>Insurance</b>	<b>GCC Clause 11.6</b>
<b>The Works</b>		
Amount of Cover : The sum stated in Letter of Acceptance plus fifteen percent 15%.		
<b>Contractor 's equipment</b>		
Amount of Cover :Full replacement Cost		
<b>Injury to Person and Damaged to Property including Third party Insurance</b>		
Amount of Cover : I) As per workmen compensation act		
II) Contractor's all Risk including Third party		
III) damages to the Structure, stores if supplied by the Bank		
<b>SCC 9.</b>	<b>Place of Arbitration</b>	<b>GCC Clause 16.4</b>
Karachi .		



**(Bidding Documents, Section-3, Part-1)**

**Standard Forms**



**Form No. 01: FORM OF CONTRACT AGREEMENT**

(Stamp duty shall be borne by the contractor as per the prevailing rates)

THIS CONTRACT AGREEMENT (hereinafter called the "Agreement") made on the \_\_\_\_ day of \_\_\_\_ 20\_\_ between \_\_\_\_\_, acting through its \_\_\_\_\_ who is duly authorized in this behalf (hereinafter called the "Employer") and \_\_\_\_\_, acting through its \_\_\_\_\_ who is duly authorized in this behalf (hereinafter called the "Contractor").

**WHEREAS:**

- (A) The Contractor has offered to execute the works for Providing & fixing of Manual Barrier at SBP BSC Islamabad on the terms and conditions as set forth in this Contract; and
- (B) The Employer has agreed to engage the Contractor to carry out the Works on the terms and conditions contained in this Contract.

NOW this Agreement witnesses as follows:

1. In this Agreement words and expressions shall have the same meanings as are respectively assigned to them in the Conditions of Contract hereinafter referred to.
2. The following documents after incorporating addenda, if any except those parts relating to Instructions to Bidders, shall be deemed to form and be read and construed as part of this Agreement, and in case of any conflict the decision of Director Engineering shall be final and binding.
  - (a) The Letter of Acceptance;
  - (b) The completed Form of Bid along with Schedules to Bid;
  - (c) Contract Data
  - (d) Conditions of Contract;
  - (e) The priced Schedule of Prices;
  - (f) The Specifications; and
  - (g) The Drawings, if any
  - (h) Addendum/Corrigendum, if any
3. In consideration of the payments to be made by the Employer to the Contractor as hereinafter mentioned, the Contractor hereby covenants with the Employer to execute and complete the Works and remedy defects therein in conformity and in all respects within the provisions of the Contract.
4. The Employer hereby covenants to pay the Contractor, in consideration of the execution and completion of the Works as per provisions of the Contract, the Contract Price or such other sum as may become payable under the provisions of the Contract at the times and in the manner prescribed by the Contract.

IN WITNESS WHEREOF the parties hereto have caused this Contract Agreement to be executed on the day, month and year first before written in accordance with their respective laws.

Name, Signature of the Contactor

Name, Signature of the Employer

(Seal)

(Seal)

Signed, Sealed and Delivered in the presence of:

Witness No.1  
(Name, Title and Address)

Witness No.1  
(Name, Title and Address)

Witness No.2  
(Name, Title and Address)

Witness No.2  
(Name, Title and Address)



**Form No. 02: FORM OF PERFORMANCE SECURITY**  
(Bank Guarantee/ Insurance Guarantee)

Guarantee No. \_\_\_\_\_  
Executed on \_\_\_\_\_

(Letter by the Guarantor to the Employer)

Name of Guarantor (Scheduled Bank in Pakistan) with Address: \_\_\_\_\_

Name of Principal (Contractor) with  
Address: \_\_\_\_\_

Penal Sum of Security (express in words and Figures) \_\_\_\_\_

Letter of Acceptance No. \_\_\_\_\_ Dated \_\_\_\_\_

KNOW ALL MEN BY THESE PRESENTS, that in pursuance of the terms of the Bidding Documents and above said Letter of Acceptance (hereinafter called the Documents) and at the request of the said Principal we, the Guarantor above named, are held and firmly bound unto the \_\_\_\_\_ (hereinafter called the Employer) in the penal sum of the amount stated above, for the payment of which sum well and truly to be made to the said Employer, we bind ourselves, our heirs, executors, administrators and successors, jointly and severally, firmly by these presents.

THE CONDITION OF THIS OBLIGATION IS SUCH, that whereas the Principal has accepted the Employer's above said Letter of Acceptance for \_\_\_\_\_ (Name of Contract) for the \_\_\_\_\_ (Name of Project).

NOW THEREFORE, if the Principal (Contractor) shall well and truly perform and fulfill all the undertakings, covenants, terms and conditions of the said Documents during the original terms of the said Documents and any extensions thereof that may be granted by the Employer, with or without notice to the Guarantor, which notice is, hereby, waived and shall also well and truly perform and fulfill all the undertakings, covenants terms and conditions of the Contract and of any and all modifications of the said Documents that may hereafter be made, notice of which modifications to the Guarantor being hereby waived, then, this obligation to be void; otherwise to remain in full force and virtue till all requirements of Clause -09, Identification & Remedying of Defects, of Conditions of Contract are fulfilled.

Our total liability under this Guarantee is limited to the sum stated above and it is a condition of any liability attaching to us under this Guarantee that the claim for payment in writing shall be received by us within the validity period of this Guarantee, failing which we shall be discharged of our liability, if any, under this Guarantee.

We, \_\_\_\_\_ (the Guarantor), waiving all objections and defenses under the Contract, do hereby irrevocably and independently guarantee to pay to the Employer without delay upon the Employer's first written demand without cavil or arguments and without requiring the Employer to prove or to show grounds or reasons for such demand any sum or sums up to the amount stated above, against the Employer's written declaration that the Principal has refused or failed to perform the obligations under the Contract, for which payment will be effected by the Guarantor to Employer's designated Bank & Account Number.

PROVIDED ALSO THAT the Employer shall be the sole and final judge for deciding whether the Principal (Contractor) has duly performed his obligations under the Contract or has defaulted in fulfilling said obligations and the Guarantor shall pay without objection any sum or sums up to the amount stated above upon first written demand from the Employer forthwith and without any reference to the Principal or any other person.

IN WITNESS WHEREOF, the above bounded Guarantor has executed this Instrument under its seal on the date indicated above, the name and corporate seal of the Guarantor being hereto affixed and these presents duly signed by its undersigned representative, pursuant to authority of its governing body.



**Form No. 03: FORM OF BANK GUARANTEE FOR ADVANCE PAYMENT**

Guarantee No. \_\_\_\_\_

Executed on \_\_\_\_\_

(Letter by the Guarantor to the Employer)

WHEREAS the \_\_\_\_\_ (hereinafter called the Employer) has entered into a Contract for \_\_\_\_\_ (Particulars of Contract), with \_\_\_\_\_ (hereinafter called the Contractor).

AND WHEREAS the Employer has agreed to advance to the Contractor, at the Contractor's request, an amount of Rs. \_\_\_\_\_ Rupees \_\_\_\_\_) which amount shall be advanced to the Contractor as per provisions of the Contract.

AND WHEREAS the Employer has asked the Contractor to furnish Guarantee to secure the advance payment for the performance of his obligations under the said Contract.

AND WHEREAS \_\_\_\_\_ (Scheduled Bank) (hereinafter called the Guarantor) at the request of the Contractor and in consideration of the Employer agreeing to make the above advance to the Contractor, has agreed to furnish the said Guarantee.

NOW THEREFORE the Guarantor hereby guarantees that the Contractor shall use the advance for the purpose of above mentioned Contract and if he fails, and commits default in fulfillment of any of his obligations for which the advance payment is made, the Guarantor shall be liable to the Employer for payment not exceeding the aforementioned amount.

Notice in writing of any default, of which the Employer shall be the sole and final judge, as aforesaid, on the part of the Contractor, shall be given by the Employer to the Guarantor, and on such first written demand payment shall be made by the Guarantor of all sums then due under this Guarantee without any reference to the Contractor and without any objection. This Guarantee shall come into force as soon as the advance payment has been credited to the account of the Contractor.

This Guarantee shall expire on \_\_\_\_\_. The guarantee shall remain valid up to the final adjustment of the advance made in case of expiry without adjustment of the advance the Guarantor shall automatically renew the guarantee till such time/times as the employer may deem fit. In case the guarantee is renewed on the request of the employer the Guarantor shall be bound to renew the guarantee without reference to the contractor or any other part, the payment of the charges may be made by the employer from the payments due to the contractor or its securities.

The claim of the employer will remain valid even if the guarantee has expired until the clearance is received in writing by the employer along with the original bank Guarantee.

It is understood that Employer will return this Guarantee to Guarantor on expiry or after settlement of the total amount to be claimed hereunder.

\_\_\_\_\_



**Form No. 04: INDEMNITY BOND FOR SECURE ADVANCE AGAINST MATERIALS BROUGHT AT SITE**

(ON Rs. 500 non-judicial stamp paper)

This Deed of Indemnity is issued by M/s. \_\_\_\_\_ (name of the contractor) in favour of M/s. \_\_\_\_\_ (name of the employer).

**Whereas** \_\_\_\_\_ (herein called the Employer) has paid the Secure Advance against the cost of material through any Bank or like agency by any other method by virtue of terms of the contract existing between the parties. The details of the material and their price for which secured advance is sought for the period \_\_\_\_\_ till consumption of the material is as under:-

- 1. \_\_\_\_\_ at Rs. \_\_\_\_\_ per \_\_\_\_\_ = Rs.
- 2. \_\_\_\_\_ at Rs. \_\_\_\_\_ per \_\_\_\_\_ = Rs.
- 3. \_\_\_\_\_ at Rs. \_\_\_\_\_ per \_\_\_\_\_ = Rs.

THEREFORE THIS DEED OF INDEMNITY WITNESSETH AS FOLLOWS:

I/We \_\_\_\_\_ of M/s. \_\_\_\_\_ do hereby indemnify M/s. \_\_\_\_\_ for all losses due to thefts, arson, pilferage, loss due to flood and inundation, shortage, deterioration and depreciation etc. through any act of Man or God or slump in the Market of any or all the materials financed or paid by the Employer on our request for financing payment against material.

I/We \_\_\_\_\_ shall indemnify \_\_\_\_\_ against any or all claims, action damages arising out of or resulting to the said material.

I/We \_\_\_\_\_ further declare that we will faithfully abide by the above declaration and solemnly affirm that we will not remove, sell, pilferage any of the materials against which M/s. \_\_\_\_\_ has paid us such a secured advance and will not pledge the same with any Bank, Finance Corporation, Firm, Company, Individual or the like agency or create any change whereon in any form what so ever.

I/We \_\_\_\_\_ do hereby also declare that in the event of my/our infringement of the declaration made above \_\_\_\_\_ will be entitled to forfeit all such material and also proceed against me/us according to the relevant clause pertaining to breach of contract and further invoke the power or seek any remedies secured of \_\_\_\_\_ under the contract Agreement signed with us or otherwise available under law.

Place \_\_\_\_\_ Dated \_\_\_\_\_

Contractor \_\_\_\_\_

**Witness:**

Signature \_\_\_\_\_

Name \_\_\_\_\_

**Witness:**

Signature \_\_\_\_\_

Name \_\_\_\_\_



Form of Declaration of Ultimate Beneficial Owners Information

**Declaration of Ultimate Beneficial Owners Information for Public Procurement Contracts**

1. Name
2. Father's Name/Spouse's Name
3. CNIC/NICOP/Passport no.
4. Nationality
5. Residential address
6. Email address
7. Date on which shareholding, control or interest acquired in the business.
8. In case of indirect shareholding, control or interest being exercised through intermediary companies, entities or other legal persons or legal arrangements in the chain of ownership or control, following additional particulars to be provided:

1	2	3	4	5	6	7	8	9	10
Name	Legal form (Company/Limited Liability Partnership/Association of Persons/Single Member Company/ Partnership Firm/ Trust/Any other individual, body corporate (to be specified))	Date of incorporation/ registration	Name of registering authority	Business Address	Country	Email address	Percentage of shareholding, control or interest of BO in the legal person or legal arrangement	Percentage of shareholding, control or interest of legal person or legal arrangement in the Company	Identity of Natural Person who ultimately owns or controls the legal person or arrangement





9. Information about the Board of Directors (details shall be provided regarding number of shares in the capital of the company as set opposite respective names).

1	2	3	4	5	6	7	8
Name and surname (In Block Letters)	CNIC No. (in case of foreigner, Passport No)	Father's/ Husband's Name in full	Current Nationality	Any other Nationality (ies)	Occupation	Residential address in full or the registered/ principal office address for a subscriber other than natural person	Number of shares taken by each subscriber (in figures and words)
			Total number of shares taken (in figures and words)				

10. Any other information incidental to or relevant to Beneficial Owner(s).

Name & signature

(Person authorized to issue notice on behalf of the company)



*(Bidding Documents, Section-3, Part-2)*

**SPECIFICATIONS**



**(Bidding Documents, Section-3, Part-3)**

**DRAWINGS**



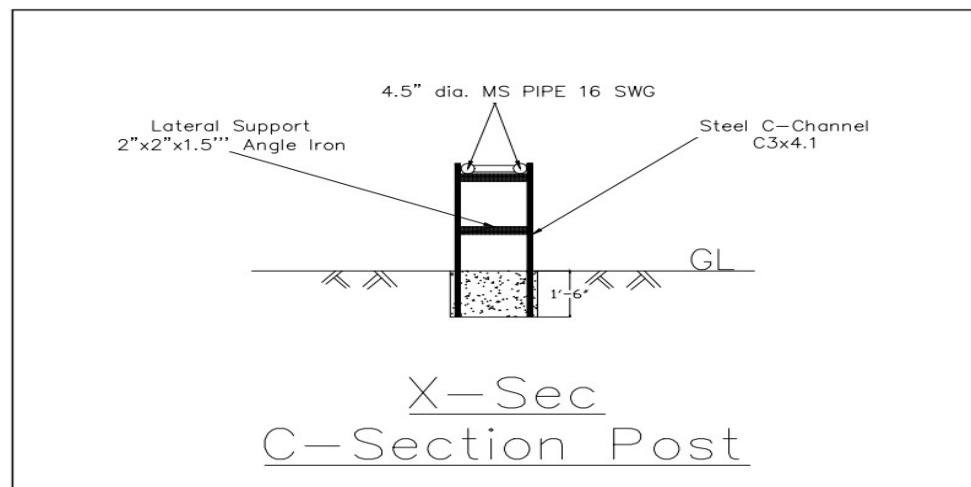
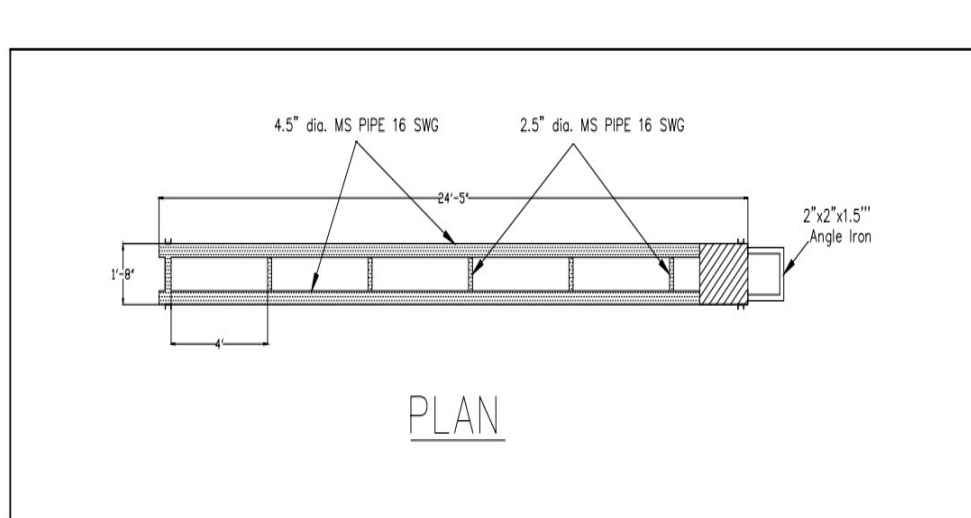
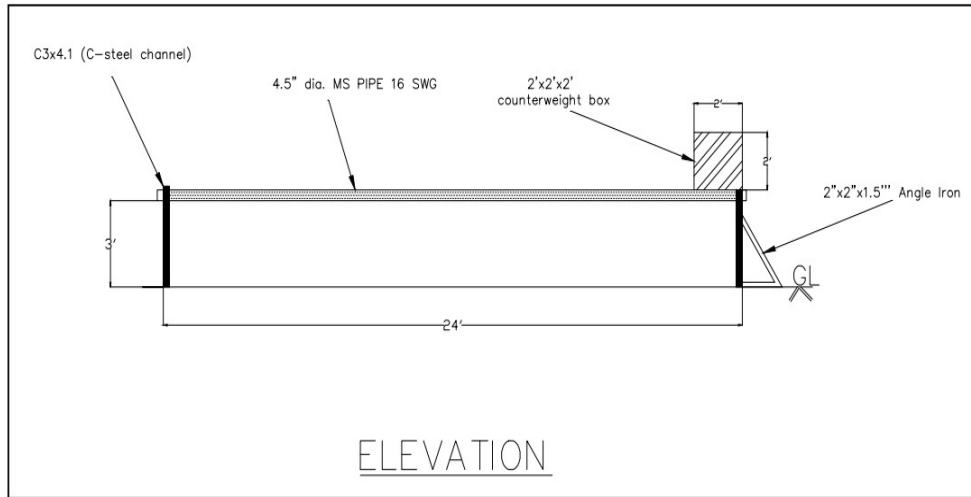



STATE BANK OF PAKISTAN  
SBP BANKING SERVICES CORPORATION

---

PROVIDING & FIXING OF MANUAL BARRIER IN FRONT OF MAIN GATE AT SBP BSC  
ISLAMABAD

---

BIDDING AND CONTRACT DOCUMENT

VOLUME-II

**FINANCIAL BID**

**JANUARY 2024**



## SCHEDULE-A TO BID

### Financial Bid/ Schedule of Prices

#### PROVIDING & FIXING OF MANUAL BARRIER IN FRONT OF MAIN GATE AT SBP BSC ISLAMABAD

#### 1. PREAMBLE

- i. The items mentioned in Bill of Quantities consist of furnishing all plants, labour, equipment, machinery appliances, materials, fittings, fixtures and fabrication, erection, installation, lifting of materials required for completing the items/works and the work shall be done in accordance with Bill of Quantities, specifications and drawings complete in all respects.
- ii. The quantities contained in the Bill of Quantities are approximate estimated quantities and liable to be changed (increased/decreased) or omitted when the work will be actually executed. The Employer is authorized to delete any item of work or vary quantities of any item(s) of Bill of Quantities. No claim for any adjustment in the unit rate set forth in the Bill of Quantities will be made because of any increase or any decrease in the quantities indicated herein.
- iii. The prices and rates to be quoted in the Bill of Quantities are to be the full inclusive value of the works described under specified items including all cost of expenses which may be required in and for the construction of the works described and implied in all the documents referred to on which the tender is based.
- iv. Rates quoted should be inclusive of all applicable taxes, duties, levies etc.
- v. Unit rate is to be entered against each item in the Bill of Quantities whether quantities are entered or not. Items against which no price or rate is quoted in the Bill of Quantities shall be deemed to have been covered by rates or prices quoted in the other BOQ item.
- vi. Sub-total/Total amounts shall also be referred in words.
- vii. Where there is a discrepancy between the unit rate and the line item total resulting from multiplying the unit rate by the quantity, the unit rate as quoted will govern, and the line total will be corrected accordingly.
- viii. Each cutting should be signed by the authorized person.
- ix. The brand names have been provided in order to establish a standard of performance and reliability. However, it does not indicate a preference for a particular brand. The bidder may propose other brands, which can be accepted subject to necessary tests to establish equivalency at bidder's cost.



**BILL OF QUANTITIES:**

S #	Description	Unit	Qty.	Rate (Rs.)	Amount (Rs.)
1	Dismantling of flooring/sub flooring required for removal of existing barrier including removal of existing boom pipe frame, C-channel supports and their foundations, counter weight and other sections, stacking all materials at designated place inside the Bank premises and disposal of debris etc., complete in all respects as directed by the Engineer in-charge (EIC).	Job	01		
2	Re-fixing of old barrier removed under item no-01 above at new location including the cost of required alteration works for reducing the length, provision of additional materials required for complete installation of the barrier like dismantling & restoration of existing flooring & sub-flooring, excavation for fixing of steel C-channels supports using PCC (1:2:4) in about 2ft x 2ft x 2ft size foundations on both side, cutting/ welding etc. where required, complete as per site requirements and as directed by the Engineer In-charge.	Job	01		
3	Providing & fixing of new manual type barrier having 24 ft clear length/distance between two end supports, comprising of boom made from two MS pipes of 16 SWG 4.5" dia, each pipe extending beyond the supports by about 6" on one side and by about 2ft to 3ft on the other side (or the length required for fixing of counterweight box), both pipes of the boom arm connected together by 2.5" dia. steel pipes of 16SWG welded to both main pipes in perpendicular direction at about 4 ft c/c, barrier supported on both ends over supports made from steel channels C3x4.1, revolving at pivot point duly welded with frame and consisting of 1" dia solid steel rod and ball bearings etc., support assemblies securely anchored into the ground upto almost 2ft to 3ft depth in PCC (1:2:4) foundation of about 2ftx2ftx3ft size for both sides, ensuring proper stability & alignment of the boom arm, operated through weight bases operation integrating a counterweight into the system to facilitate raising & lowering of the boom arm with minimal physical effort consisting of suitable dimension of box having 12 SWG thick sheet all	Job	01		



S #	Description	Unit	Qty.	Rate (Rs.)	Amount (Rs.)
	around, provision of 1" dia rope, restoration/repairing of floor area as per existing design & pattern, provision of reflective coating/material for visibility during the day & night, applying two coats of red oxide, three coats of matt enamel paint of NIPPON, Berger or approved equivalent as per site requirements, drawings and as per the direction of Engineer In-charge. Moreover back filling of already excavated trench as per point 1 to be done with PCC (1:2:4) in 6" thickness at top surface of excavated soil.				
<b>TOTAL AMOUNT (RS.)=</b>					

**Total Amount Rs. (In words)**

---

**Undertaking by the Bidder:**

I \_\_\_\_\_ had visited the site and have fully understood the scope of work & specifications. The above rates are inclusive of all labor charges, Tool & Plants, applicable taxes/ duties, overheads, safety equipment's/PPEs/measures etc. I/ we have sufficient resources to carry out above works. All the above Terms & Conditions are acceptable to us. We are not blacklisted by the Bank or any other organization.

**Date:**

**Contractors Signature & Seal**

